

Chapter 8

I/O

I/O: Connecting to Outside World

So far, we've learned how to:

- **compute with values in registers**
- **load data from memory to registers**
- **store data from registers to memory**

But where does data in memory come from?

And how does data get out of the system so that humans can use it?

I/O: Connecting to the Outside World

Types of I/O devices characterized by:

- **behavior:** input, output, storage
 - input: keyboard, motion detector, network interface
 - output: monitor, printer, network interface
 - storage: disk, CD-ROM
- **data rate:** how fast can data be transferred?
 - keyboard: 100 bytes/sec
 - disk: 30 MB/s
 - network: 1 Mb/s - 1 Gb/s

I/O Controller

Control/Status Registers

- CPU tells device what to do -- write to control register
- CPU checks whether task is done -- read status register

Data Registers

- CPU transfers data to/from device

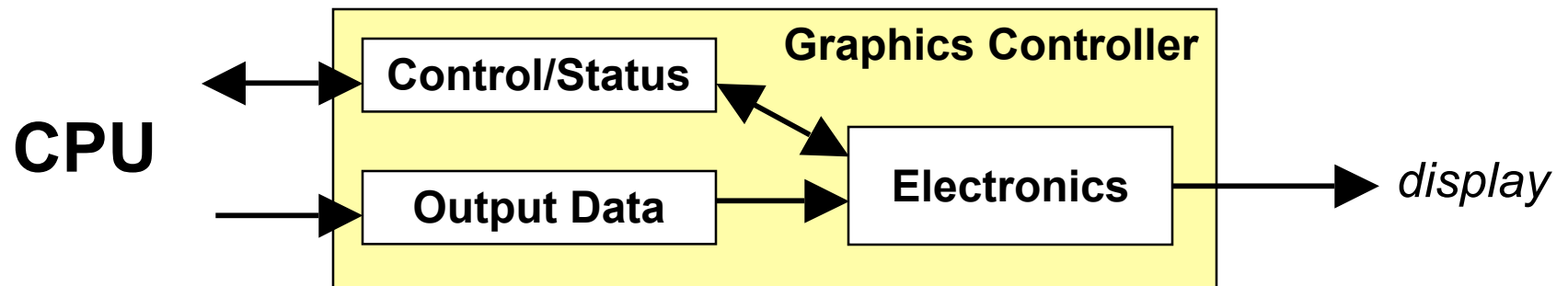

Device electronics

- performs actual operation
 - pixels to screen, bits to/from disk, characters from keyboard

Programming Interface

How are device registers identified?

- **Memory-mapped** vs. **special instructions**

How is timing of transfer managed?

- **Asynchronous** vs. **synchronous**

Who controls transfer?

- CPU (**polling**) vs. device (**interrupts**)

Memory-Mapped vs. I/O Instructions

Instructions

- designate opcode(s) for I/O
- register and operation encoded in instruction



Memory-mapped

- assign a memory address to each device register
- use data movement instructions (LD/ST) for control and data transfer

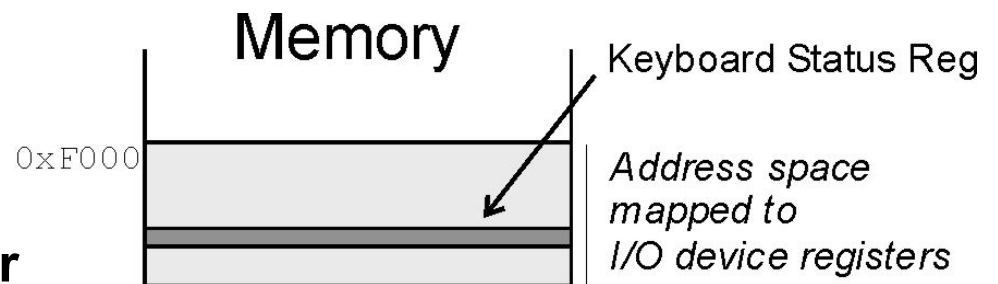

Transfer Timing

I/O events generally happen much slower than CPU cycles.

Synchronous

- data supplied at a fixed, predictable rate
- CPU reads/writes every X cycles

Asynchronous

- data rate less predictable
- CPU must synchronize with device, so that it doesn't miss data or write too quickly

Transfer Control

Who determines when the next data transfer occurs?

Polling

- CPU keeps checking status register until new data arrives OR device ready for next data
- “Are we there yet? Are we there yet? Are we there yet?”

Interrupts

- Device sends a special signal to CPU when new data arrives OR device ready for next data
- CPU can be performing other tasks instead of polling device.
- “Wake me when we get there.”

LC-3

Memory-mapped I/O (Table A.3)

<i>Location</i>	<i>I/O Register</i>	<i>Function</i>
xFE00	Keyboard Status Reg (KBSR)	Bit [15] is one when keyboard has received a new character.
xFE02	Keyboard Data Reg (KBDR)	Bits [7:0] contain the last character typed on keyboard.
xFE04	Display Status Register (DSR)	Bit [15] is one when device ready to display another char on screen.
xFE06	Display Data Register (DDR)	Character written to bits [7:0] will be displayed on screen.

Asynchronous devices

- synchronized through status registers

Polling and Interrupts

- the details of interrupts will be discussed in Chapter 10

Input from Keyboard

When a character is typed:

- its ASCII code is placed in bits [7:0] of KBDR (bits [15:8] are always zero)
- the “ready bit” (KBSR[15]) is set to one
- keyboard is disabled -- any typed characters will be ignored

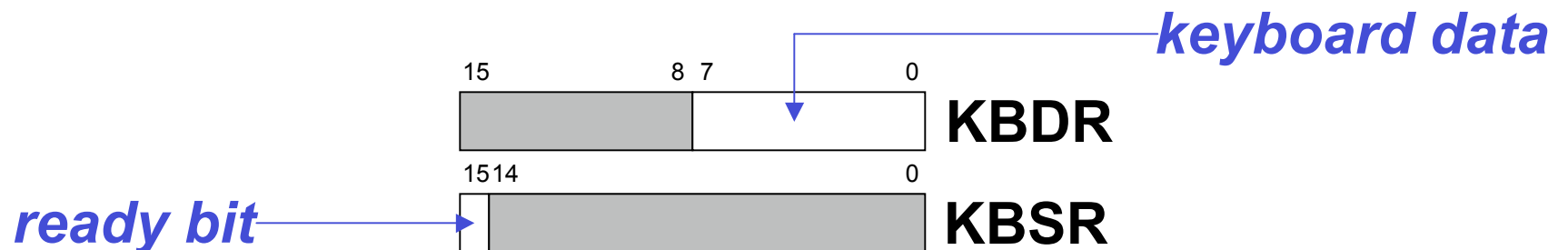

When KBDR is read:

- KBSR[15] is set to zero
- keyboard is enabled

Basic Input Routine

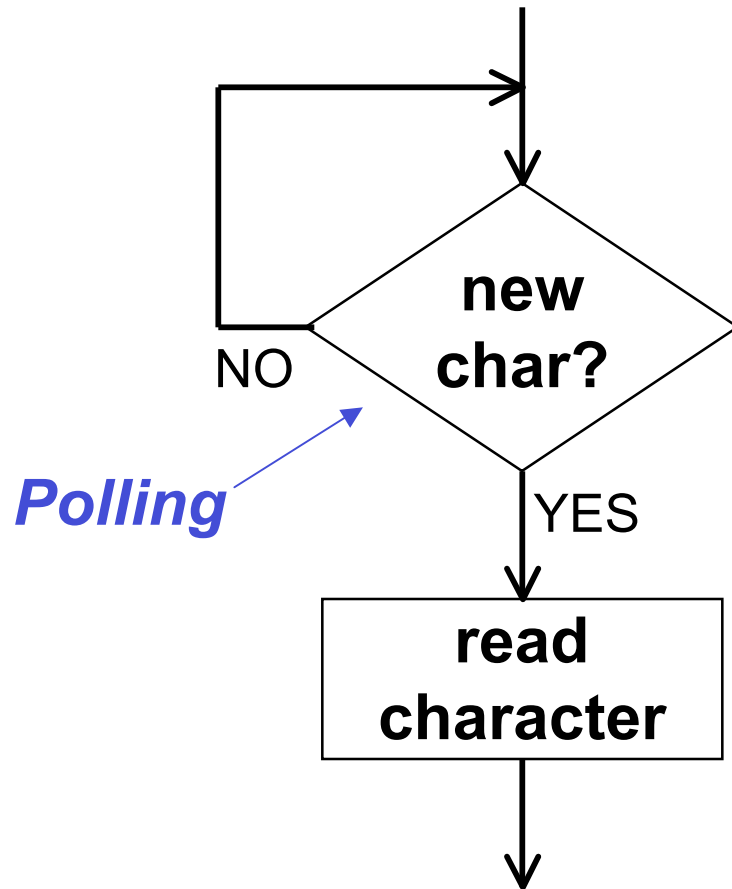

```
POLL    LDI    R0, KBSRPtr  
        BRzp  POLL  
        LDI    R0, KBDRPtr  
  
        . . .  
  
KBSRPtr .FILL  xFE00  
KBDRPtr .FILL  xFE02
```

Simple Implementation: Memory-Mapped Input

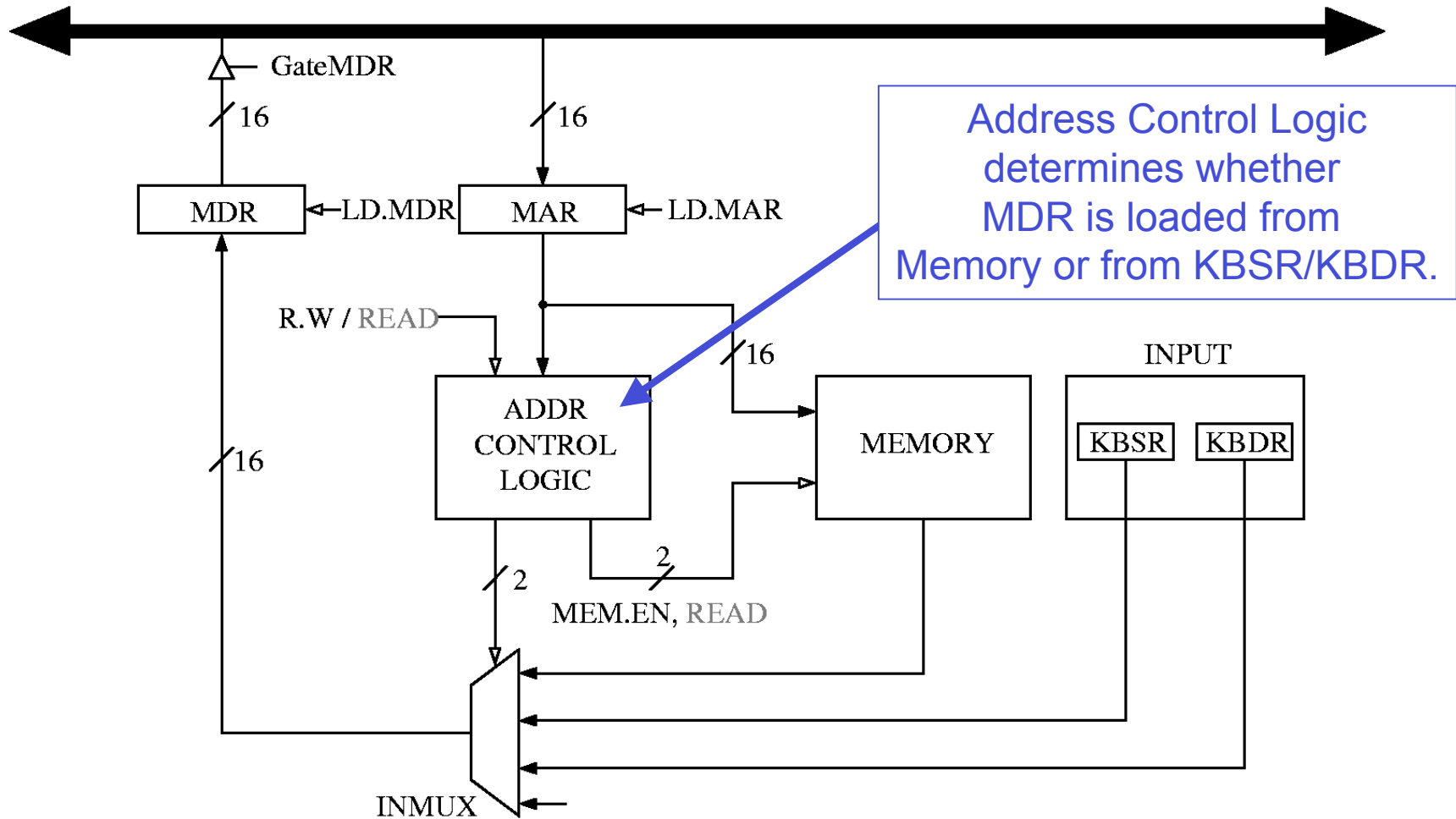

Output to Monitor

When Monitor is ready to display another character:

- the “ready bit” (DSR[15]) is set to one

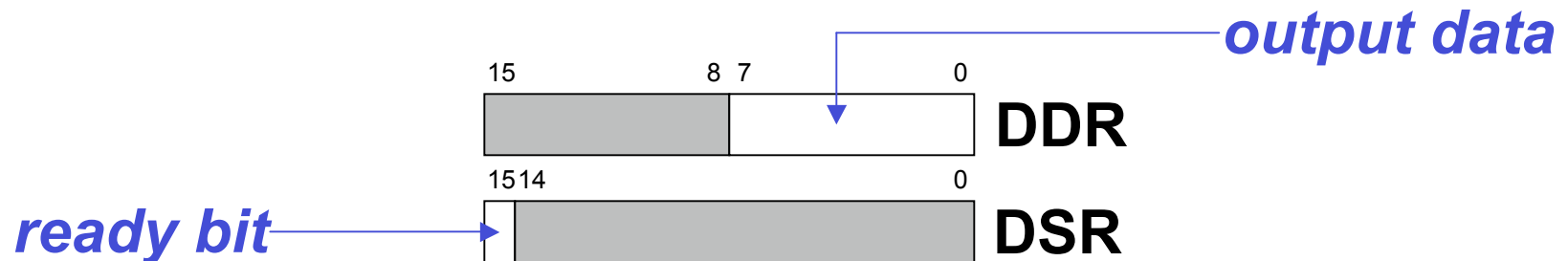

When data is written to Display Data Register:

- DSR[15] is set to zero
- character in DDR[7:0] is displayed
- any other character data written to DDR is ignored (while DSR[15] is zero)

Basic Output Routine

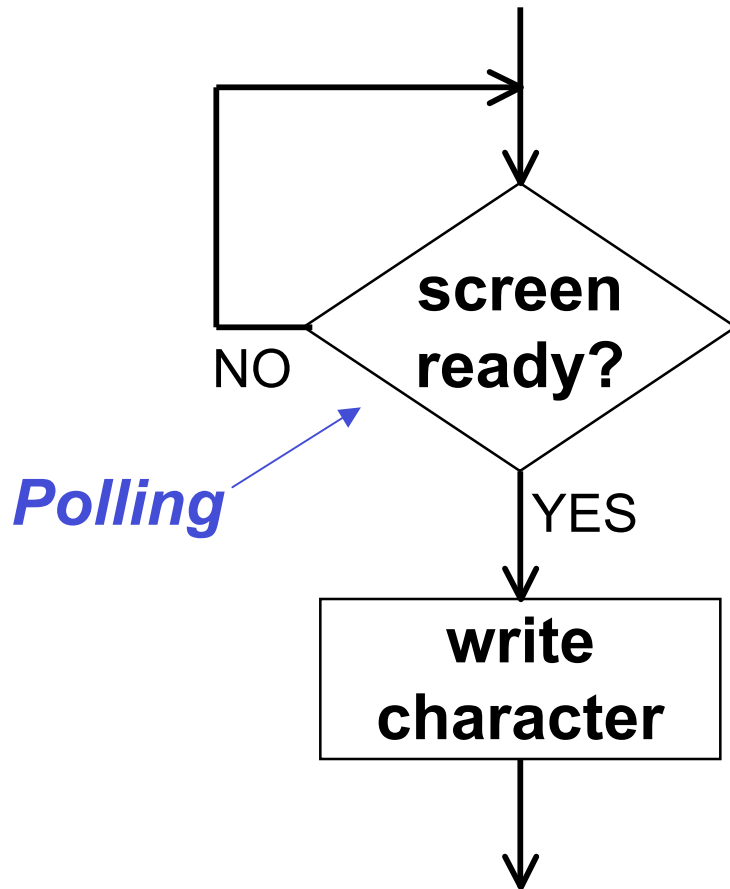

```
POLL    LDI    R1, DSRPtr  
        BRzp  POLL  
        STI    R0, DDRPtr  
  
        ...  
  
DSRPtr  .FILL  xFE04  
DDRPtr  .FILL  xFE06
```

Simple Implementation: Memory-Mapped Output

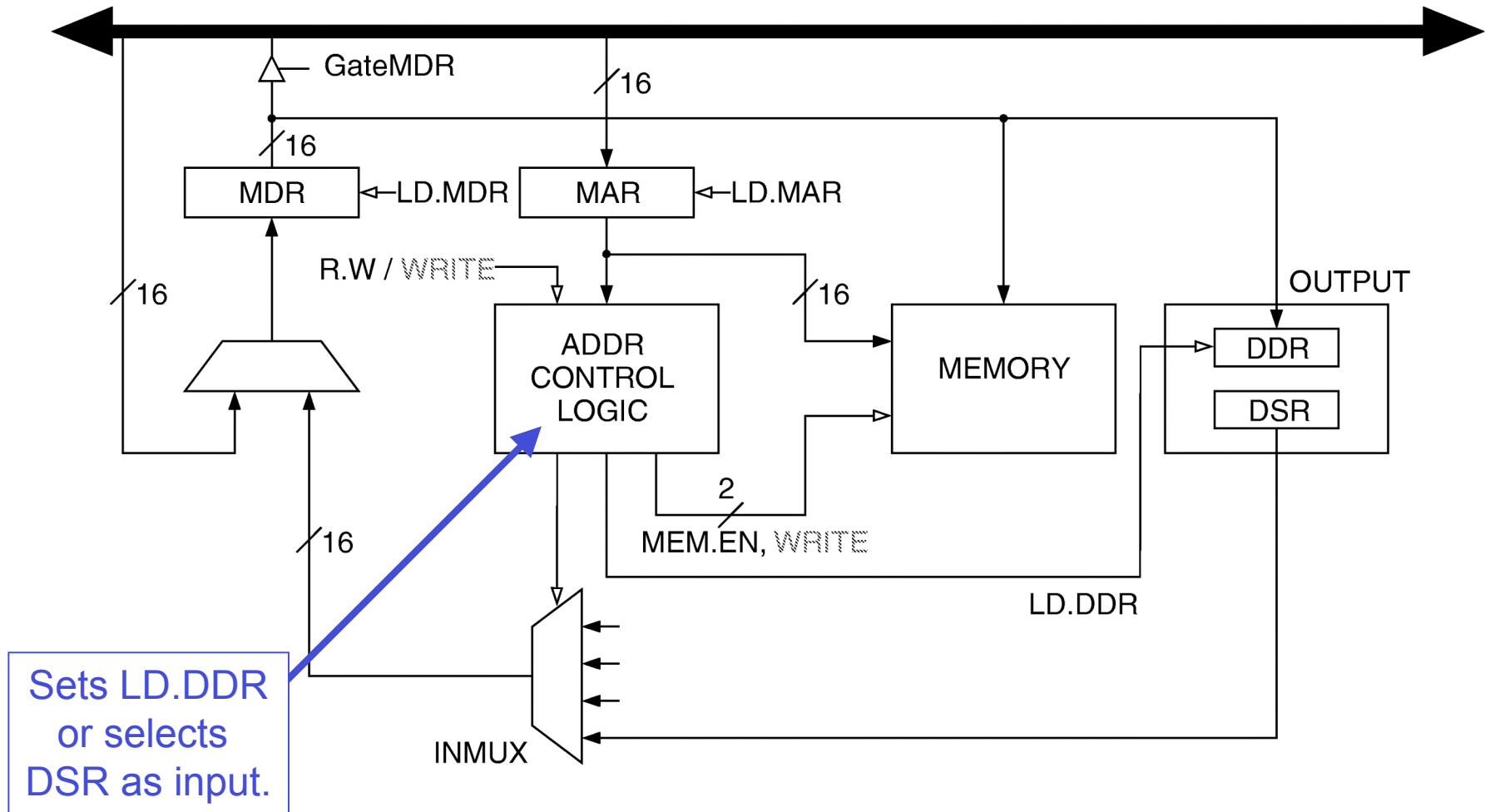

Keyboard Echo Routine

Usually, input character is also printed to screen.

- User gets feedback on character typed and knows its ok to type the next character.

```
POLL1    LDI    R0, KBSRPtr
          BRzp  POLL1
          LDI    R0, KBDRPtr
POLL2    LDI    R1, DSRPtr
          BRzp  POLL2
          STI    R0, DDRPtr
          . . .

KBSRPtr  .FILL  xFE00
KBDRPtr  .FILL  xFE02
DSRPtr   .FILL  xFE04
DDRPtr   .FILL  xFE06
```

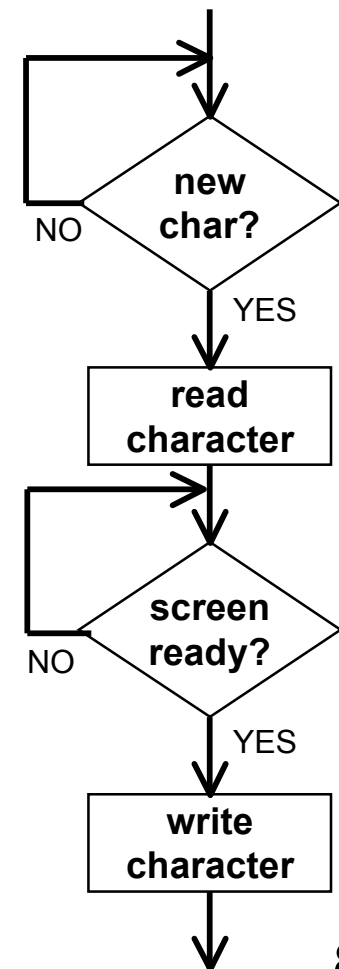

Interrupt-Driven I/O

External device can:

- (1) Force currently executing program to stop;**
- (2) Have the processor satisfy the device's needs; and**
- (3) Resume the stopped program as if nothing happened.**

Why?

- **Polling consumes a lot of cycles, especially for rare events – these cycles can be used for more computation.**
- **Example: Process previous input while collecting current input. (See Example 8.1 in text.)**

Interrupt-Driven I/O

To implement an interrupt mechanism, we need:

- A way for the I/O device to **signal** the CPU that an interesting event has occurred.
- A way for the CPU to **test** whether the **interrupt signal is set** and whether its **priority is higher** than the current program.

Generating Signal

- Software sets "interrupt enable" bit in device register.
- When ready bit is set and IE bit is set, interrupt is signaled.

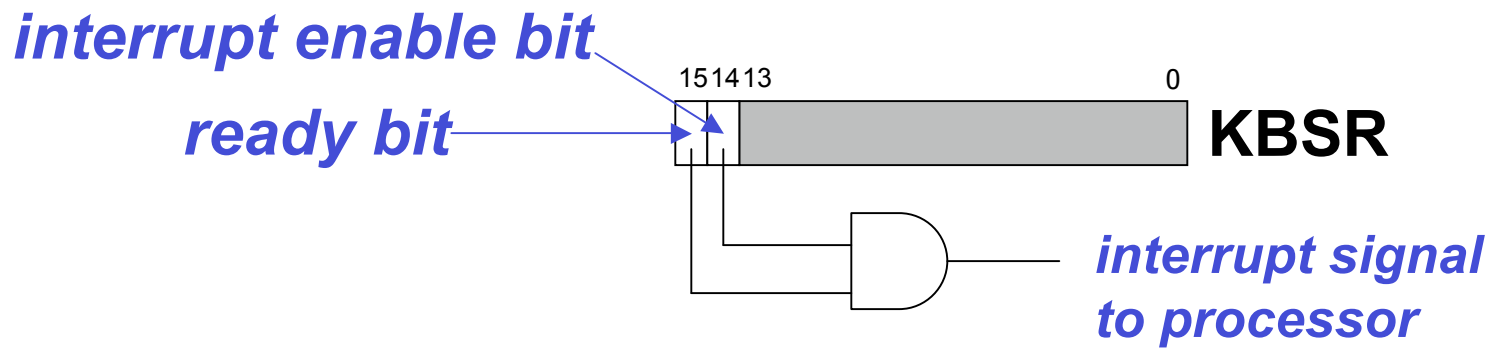

Priority

Every instruction executes at a stated level of urgency.

LC-3: 8 priority levels (PL0-PL7)

- **Example:**
 - **Payroll program runs at PL0.**
 - **Nuclear power correction program runs at PL6.**
- **It's OK for PL6 device to interrupt PL0 program, but not the other way around.**

Priority encoder selects highest-priority device, compares to current processor priority level, and generates interrupt signal if appropriate.

Full Implementation of LC-3 Memory-Mapped I/O

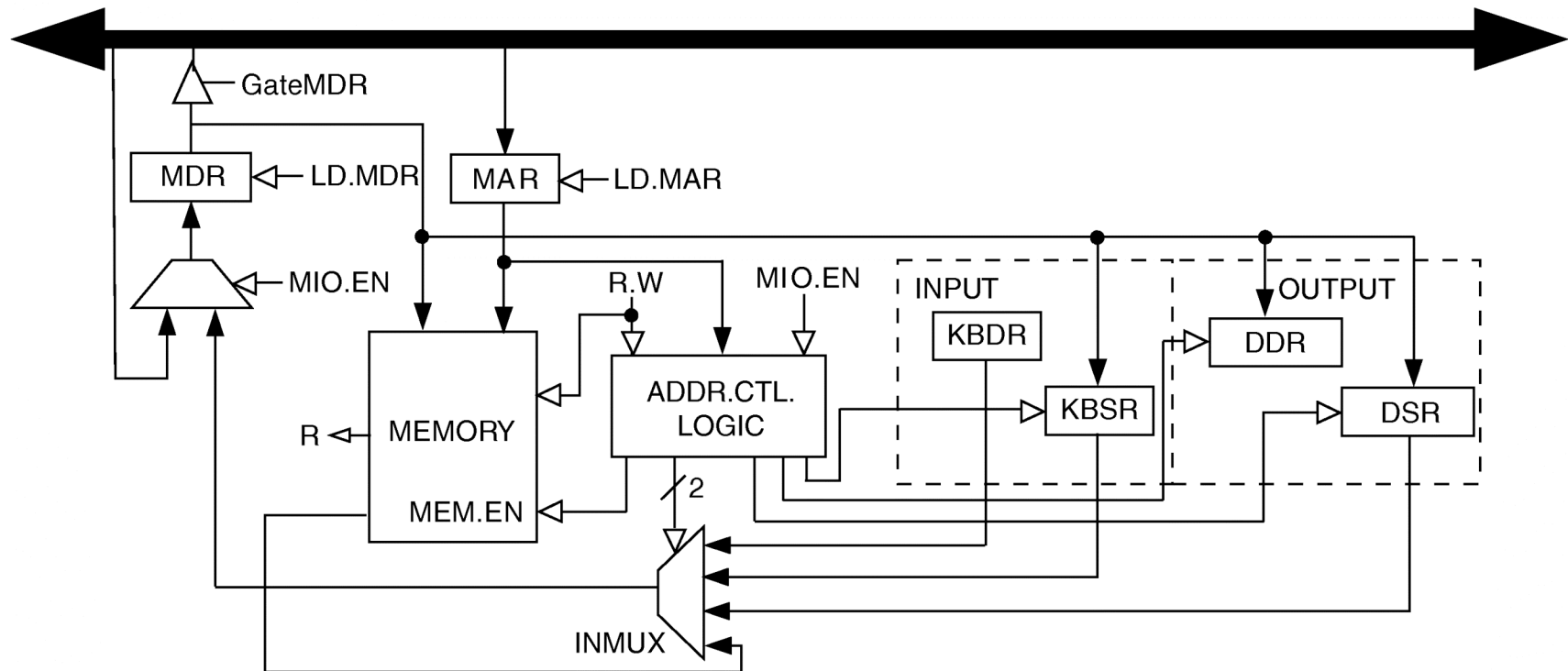

Because of interrupt enable bits, status registers (KBSR/DSR) must be written, as well as read.

Review Questions

What is the danger of not testing the DSR before writing data to the screen?

What is the danger of not testing the KBSR before reading data from the keyboard?

What if the Monitor were a synchronous device, e.g., we know that it will be ready 1 microsecond after character is written.

- **Can we avoid polling? How?**
- **What are advantages and disadvantages?**

Review Questions

Do you think polling is a good approach for other devices, such as a disk or a network interface?

What is the advantage of using LDI/STI for accessing device registers?