

Chapter 9

TRAP Routines and Subroutines

System Calls

Certain operations require **specialized knowledge** and **protection**:

- specific knowledge of I/O device registers and the sequence of operations needed to use them
- I/O resources shared among multiple users/programs; a mistake could affect lots of other users!

Not every programmer knows (or wants to know) this level of detail

Provide ***service routines*** or ***system calls*** (part of operating system) to safely and conveniently perform low-level, privileged operations

System Call

1. User program invokes system call.
2. Operating system code performs operation.
3. Returns control to user program.

In LC-3, this is done through the ***TRAP mechanism***.

LC-3 TRAP Mechanism

1. A set of service routines.

- **part of operating system -- routines start at arbitrary addresses**
(convention is that system code is below x3000)
- **up to 256 routines**

2. Table of starting addresses.

- **stored at x0000 through x00FF in memory**
- **called System Control Block in some architectures**

3. TRAP instruction.

- **used by program to transfer control to operating system**
- **8-bit trap vector names one of the 256 service routines**

4. A linkage back to the user program.

- **want execution to resume immediately after the TRAP instruction**

TRAP Instruction

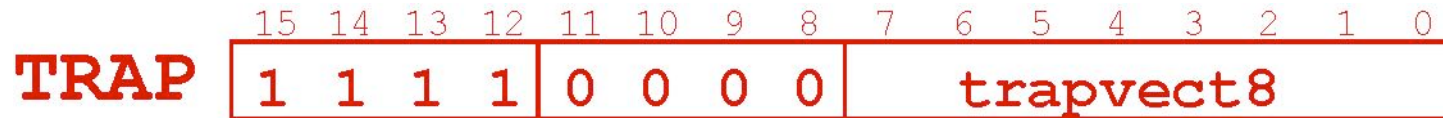

Trap vector

- identifies which system call to invoke
- 8-bit index into table of service routine addresses
 - in LC-3, this table is stored in memory at **0x0000 – 0x00FF**
 - 8-bit trap vector is zero-extended into 16-bit memory address

Where to go

- lookup starting address from table; place in PC

How to get back

- save address of next instruction (current PC) in R7

TRAP

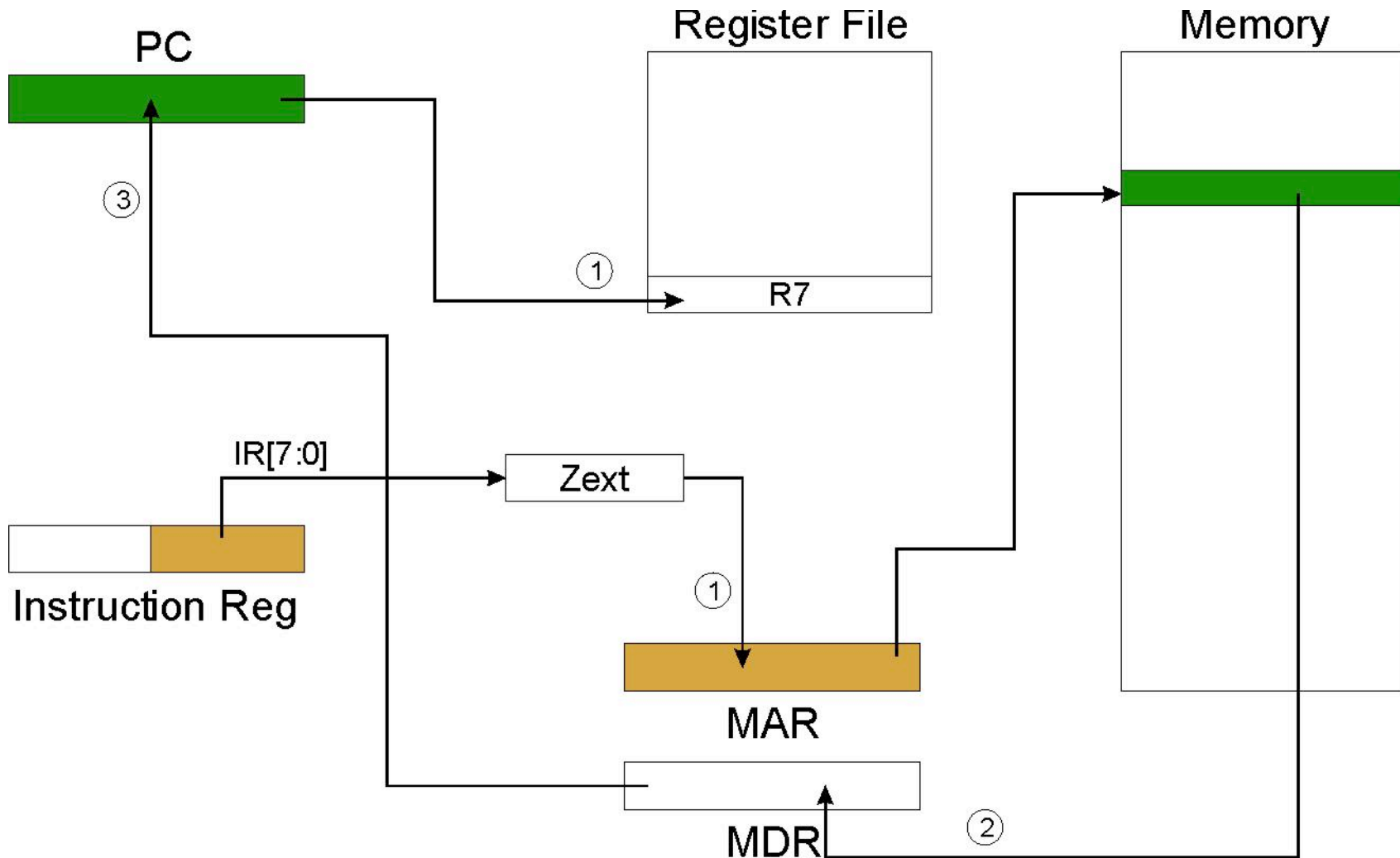

NOTE: PC has already been incremented during instruction fetch stage.

RET (JMP R7)

How do we transfer control back to instruction following the TRAP?

We saved old PC in R7.

- **JMP R7** gets us back to the user program at the right spot.
- **LC-3 assembly language** lets us use **RET** (return) in place of “JMP R7”.

Must make sure that service routine does not change R7, or we won't know where to return.

TRAP Mechanism Operation

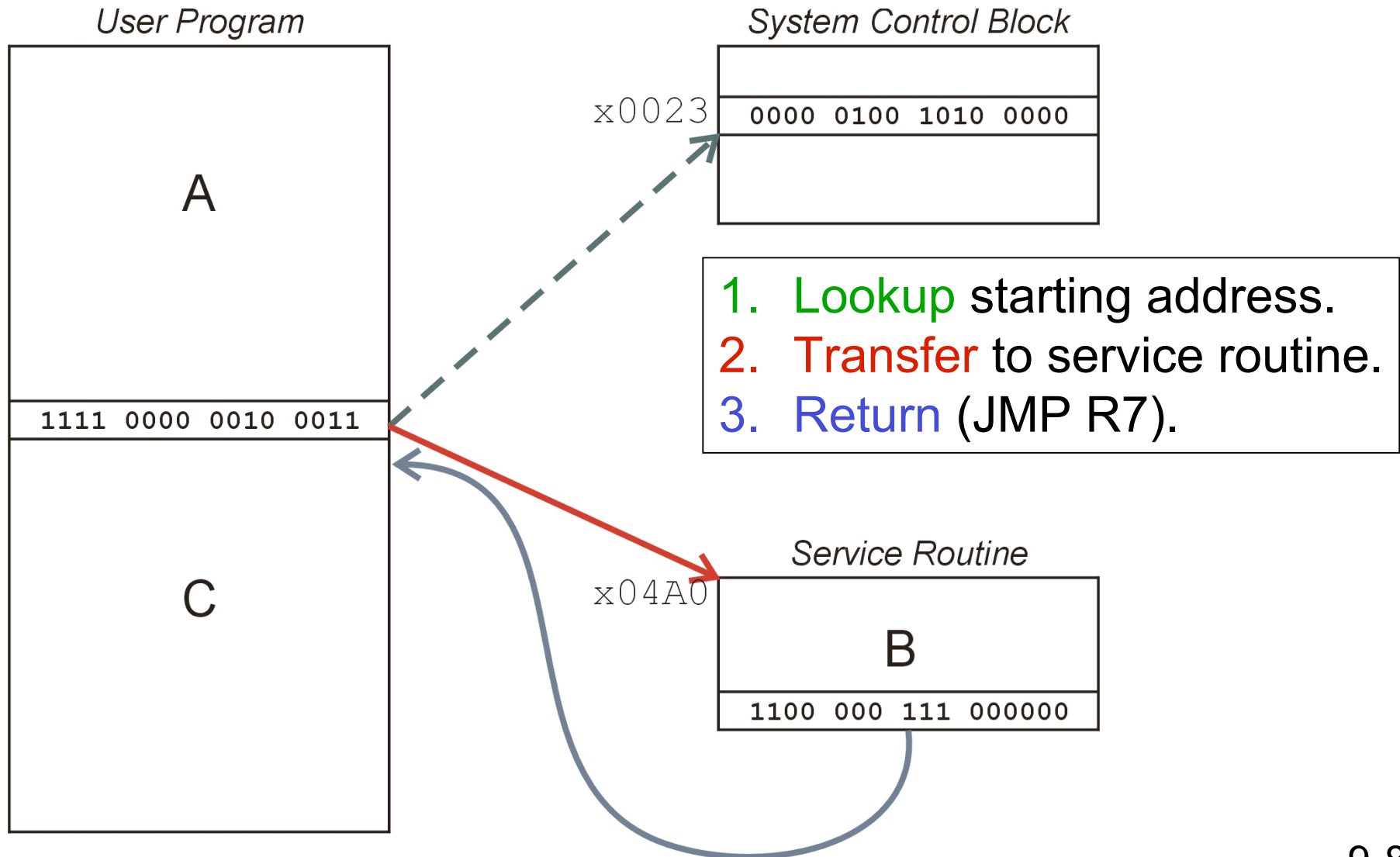

Example: Using the TRAP Instruction

```
.ORIG x3000
LD    R2, TERM    ; Load negative ASCII '7'
LD    R3, ASCII   ; Load ASCII difference
AGAIN TRAP x23     ; input character
ADD   R1, R2, R0  ; Test for terminate
BRz   EXIT       ; Exit if done
ADD   R0, R0, R3  ; Change to lowercase
TRAP  x21        ; Output to monitor...
BRnzp AGAIN      ; ... again and again...
TERM  .FILL      xFFC9    ; -'7'
ASCII .FILL      x0020    ; lowercase bit
EXIT  TRAP x25     ; halt
      .END
```

Example: Output Service Routine

```
        .ORIG x0430           ; syscall address
        ST      R7, SaveR7    ; save R7 & R1
        ST      R1, SaveR1
; ----- Write character
TryWrite LDI      R1, CRTSR    ; get status
        BRzpb TryWrite       ; look for bit 15 on
WriteIt  STI      R0, CRTDR   ; write char
; ----- Return from TRAP
Return  LD       R1, SaveR1   ; restore R1 & R7
        LD       R7, SaveR7
        RET                 ; back to user

CRTSR   .FILL    xF3FC
CRTDR   .FILL    xF3FF
SaveR1  .FILL    0
SaveR7  .FILL    0
        .END
```

stored in table,
location x21



TRAP Routines and their Assembler Names

<i>vector</i>	<i>symbol</i>	<i>routine</i>
x20	GETC	read a single character (no echo)
x21	OUT	output a character to the monitor
x22	PUTS	write a string to the console
x23	IN	print prompt to console, read and echo character from keyboard
x25	HALT	halt the program

Saving and Restoring Registers

Must save the value of a register if:

- **Its value will be destroyed by service routine, and**
- **We will need to use the value after that action.**

Who saves?

- **caller of service routine?**
 - **knows what it needs later, but may not know what gets altered by called routine**
- **called service routine?**
 - **knows what it alters, but does not know what will be needed later by calling routine**

Example

```
LEA    R3, Binary
LD     R6, ASCII    ; char->digit template
LD     R7, COUNT    ; initialize to 10
AGAIN  TRAP x23      ; Get char
ADD    R0, R0, R6    ; convert to number
STR    R0, R3, #0    ; store number
ADD    R3, R3, #1    ; incr pointer
ADD    R7, R7, -1    ; decr counter
BRp    AGAIN        ; more?
BRnzp  NEXT
ASCII  .FILL
COUNT .FILL
Binary .BLKW #10
```

What's wrong with this routine?
What happens to R7?

Saving and Restoring Registers

Called routine -- *“callee-save”*

- Before start, save any registers that will be altered (unless altered value is desired by calling program!)
- Before return, restore those same registers

Calling routine -- *“caller-save”*

- Save registers destroyed by own instructions or by called routines (if known), if values needed later
 - save R7 before TRAP
 - save R0 before TRAP x23 (input character)
- Or avoid using those registers altogether

Values are saved by storing them in memory.

Question

Can a service routine call another service routine?

If so, is there anything special the calling service routine must do?

What about User Code?

Service routines provide three main functions:

- 1. Shield programmers from system-specific details.**
- 2. Write frequently-used code just once.**
- 3. Protect system resources from malicious/clumsy programmers.**

Are there any reasons to provide the same functions for non-system (user) code?

Subroutines

A **subroutine** is a program fragment that:

- lives in user space
- performs a well-defined task
- is invoked (called) by another user program
- returns control to the calling program when finished

Like a service routine, but not part of the OS

- not concerned with protecting hardware resources
- no special privilege required

Reasons for subroutines:

- reuse useful (and debugged!) code without having to keep typing it in
- divide task among multiple programmers
- use vendor-supplied *library* of useful routines

JSR Instruction

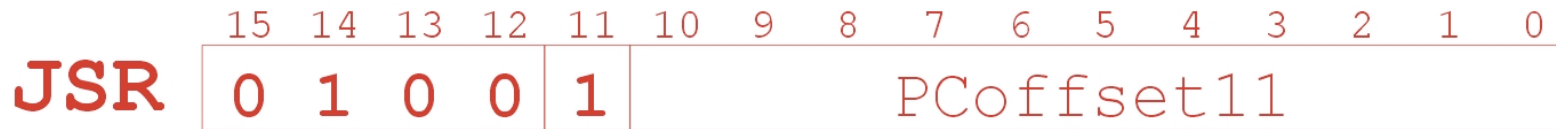

Jumps to a location (like a branch but unconditional), and saves current PC (addr of next instruction) in R7.

- saving the return address is called “linking”
- target address is PC-relative ($PC + \text{Sext}(\text{IR}[10:0])$)
- bit 11 specifies addressing mode
 - if =1, PC-relative: target address = $PC + \text{Sext}(\text{IR}[10:0])$
 - if =0, register: target address = contents of register $\text{IR}[8:6]$

JSR

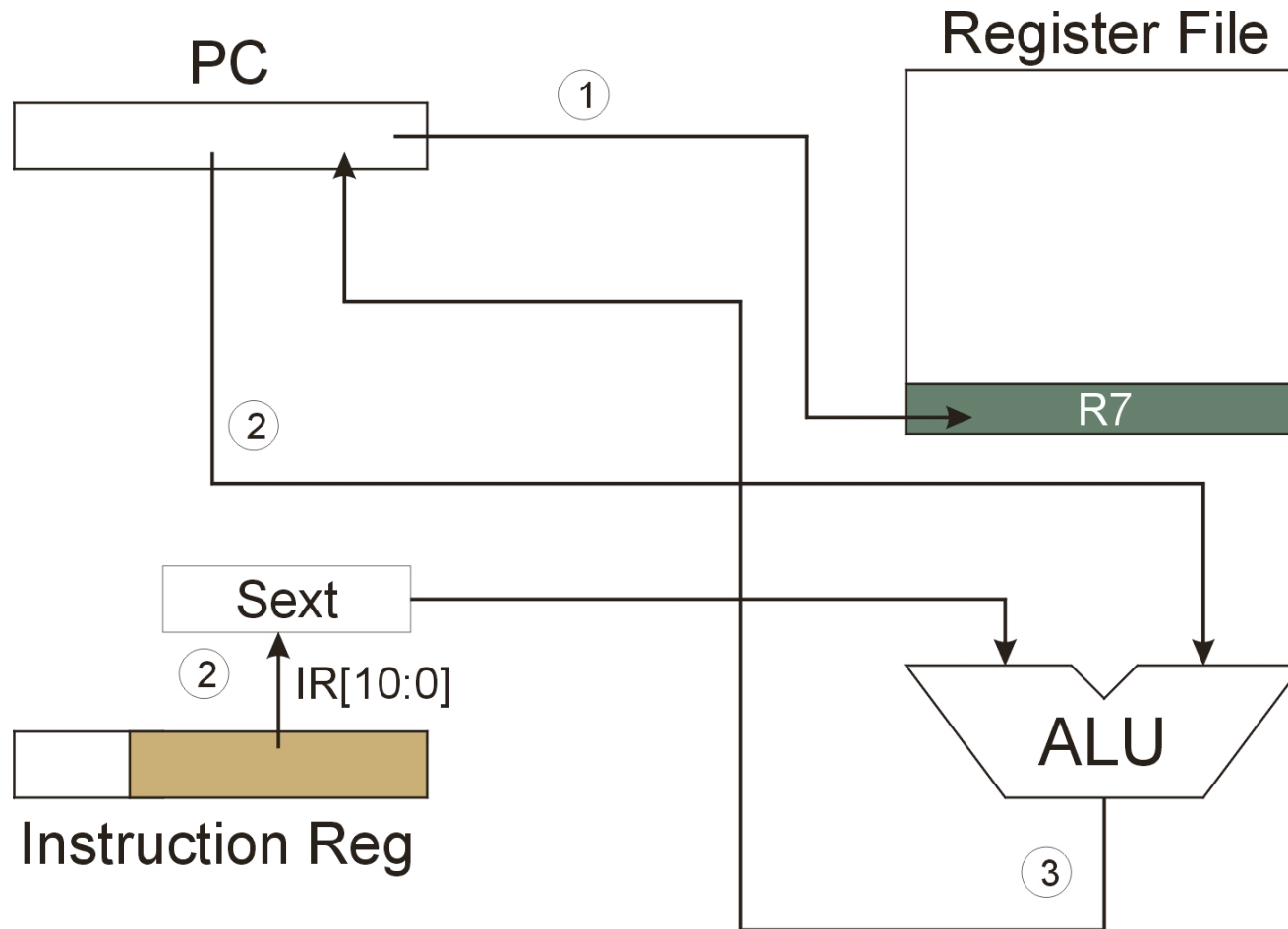

NOTE: PC has already been incremented during instruction fetch stage.

JSRR Instruction



Just like JSR, except Register addressing mode.

- target address is Base Register
- bit 11 specifies addressing mode

What important feature does JSRR provide that JSR does not?

JSRR

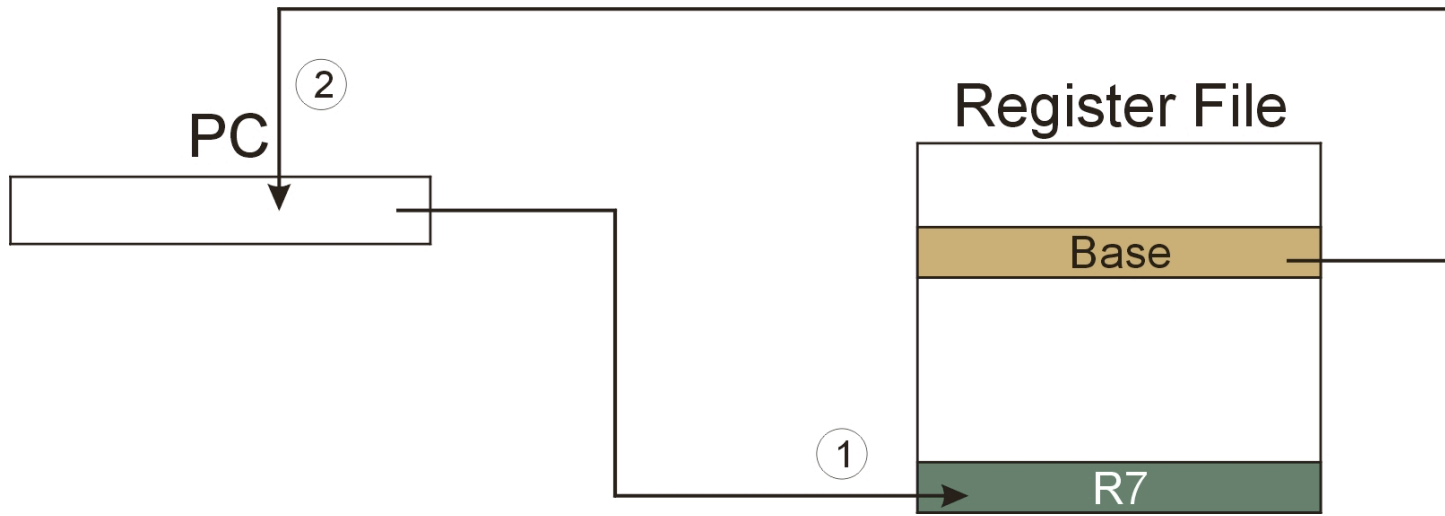

NOTE: PC has already been incremented during instruction fetch stage.

Returning from a Subroutine

RET (JMP R7) gets us back to the calling routine.

- just like TRAP

Example: Negate the value in R0

```
2sComp    NOT    R0 , R0          ; flip bits
           ADD    R0 , R0 , #1      ; add one
           RET                               ; return to caller
```

To call from a program (within 1024 instructions):

```
; need to compute R4 = R1 - R3
           ADD    R0 , R3 , #0      ; copy R3 to R0
           JSR    2sComp           ; negate
           ADD    R4 , R1 , R0      ; add to R1
           ...
```

Note: Caller should save R0 if we'll need it later!

Passing Information to/from Subroutines

Arguments

- A value **passed in** to a subroutine is called an argument.
- This is a value needed by the subroutine to do its job.
- Examples:
 - In 2sComp routine, R0 is the number to be negated
 - In OUT service routine, R0 is the character to be printed.
 - In PUTS routine, R0 is address of string to be printed.

Return Values

- A value **passed out** of a subroutine is called a return value.
- This is the value that you called the subroutine to compute.
- Examples:
 - In 2sComp routine, negated value is returned in R0.
 - In GETC service routine, character read from the keyboard is returned in R0.

Using Subroutines

In order to use a subroutine, a programmer must know:

- **its address** (or at least a label that will be bound to its address)
- **its function** (what does it do?)
 - **NOTE:** The programmer does not need to know ***how*** the subroutine works, but what changes are visible in the machine's state after the routine has run.
- **its arguments** (where to pass data in, if any)
- **its return values** (where to get computed data, if any)

Saving and Restore Registers

Since subroutines are just like service routines, we also need to save and restore registers, if needed.

Generally use “callee-save” strategy, except for return values.

- **Save anything that the subroutine will alter internally that shouldn't be visible when the subroutine returns.**
- **It's good practice to restore incoming arguments to their original values (unless overwritten by return value).**

Remember: You MUST save R7 if you call any other subroutine or service routine (TRAP).

- **Otherwise, you won't be able to return to caller.**

Example

(1) Write a subroutine **FirstChar** to:

find the first occurrence
of a particular **character** (in **R0**)
in a **string** (pointed to by **R1**);
return **pointer** to character or to end of string (NULL) in **R2**.

(2) Use **FirstChar** to write **CountChar**, which:

counts the number of occurrences
of a particular **character** (in **R0**)
in a **string** (pointed to by **R1**);
return **count** in **R2**.

**Can write the second subroutine first,
without knowing the implementation of FirstChar!**

CountChar Algorithm (using FirstChar)

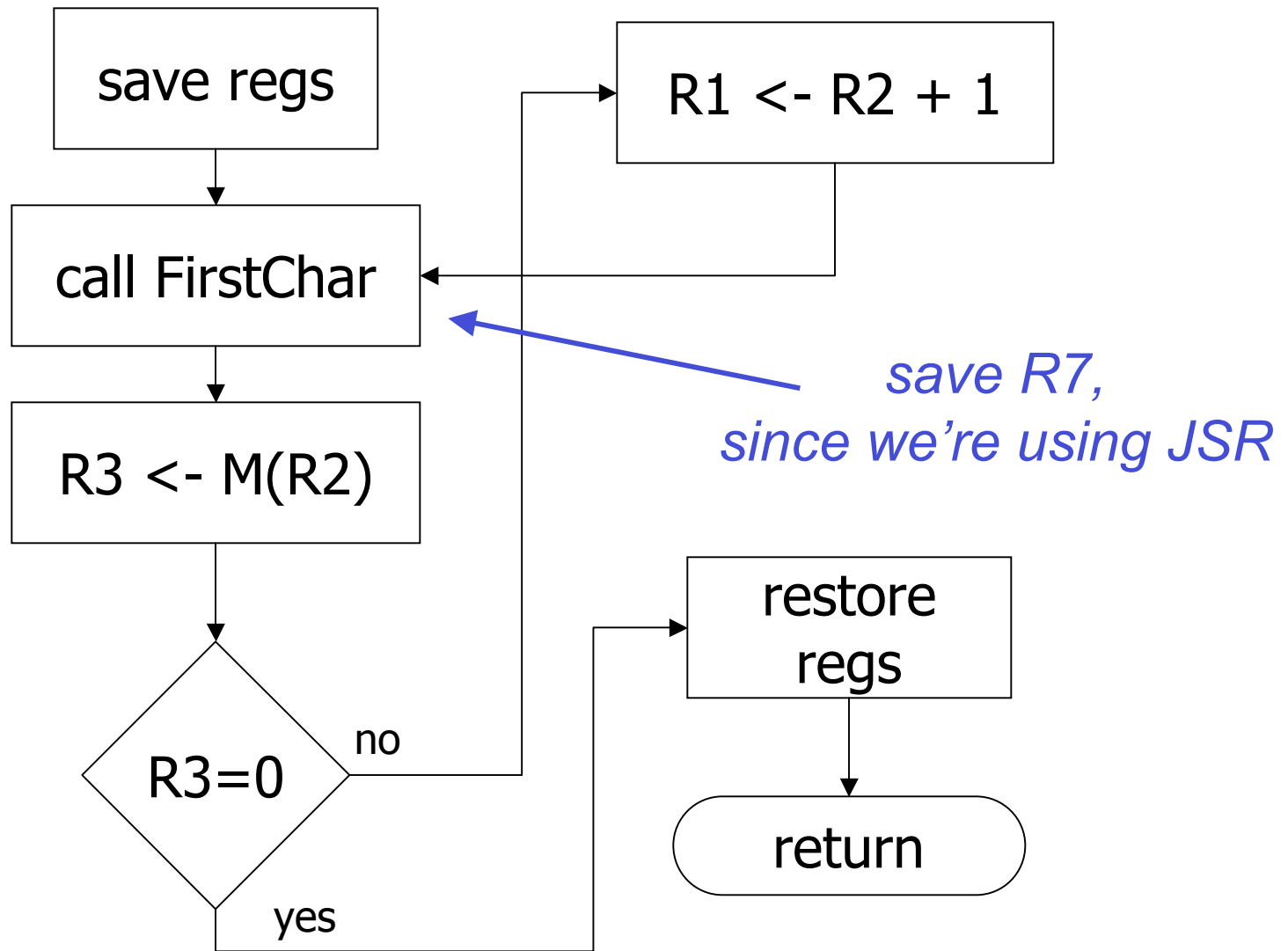

CountChar Implementation

; CountChar: subroutine to count occurrences of a char

CountChar

```

    ST    R3, CCR3    ; save registers
    ST    R4, CCR4
    ST    R7, CCR7    ; JSR alters R7
    ST    R1, CCR1    ; save original string ptr
    AND   R4, R4, #0   ; initialize count to zero
CC1    JSR  FirstChar  ; find next occurrence (ptr in R2)
    LDR   R3, R2, #0   ; see if char or null
    BRz   CC2          ; if null, no more chars
    ADD   R4, R4, #1   ; increment count
    ADD   R1, R2, #1   ; point to next char in string
BRnzp  CC1
CC2    ADD   R2, R4, #0 ; move return val (count) to R2
    LD    R3, CCR3    ; restore regs
    LD    R4, CCR4
    LD    R1, CCR1
    LD    R7, CCR7
    RET                               ; and return
```

FirstChar Algorithm

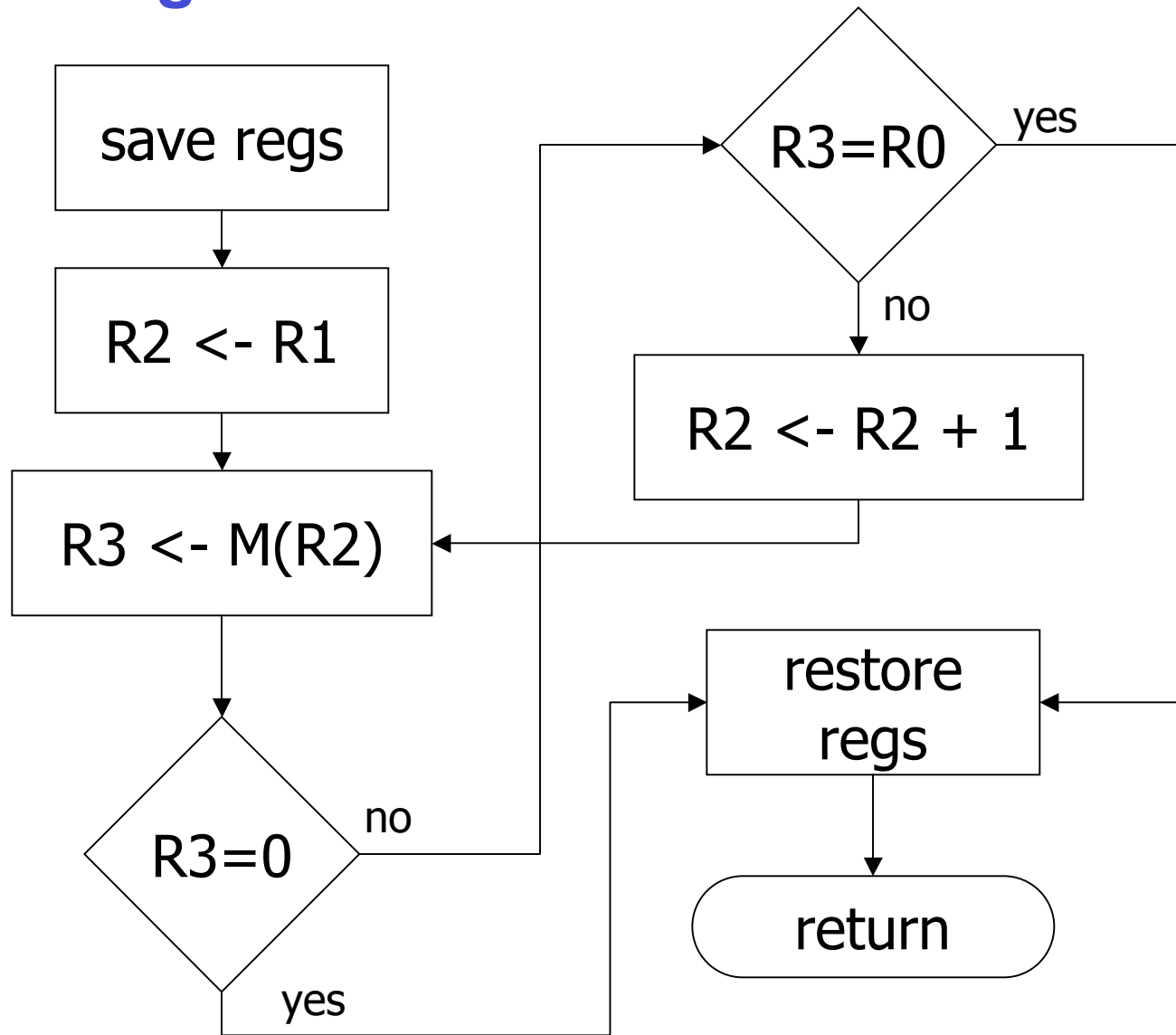

FirstChar Implementation

; FirstChar: subroutine to find first occurrence of a char

FirstChar

```

    ST    R3, FCR3    ; save registers
    ST    R4, FCR4    ; save original char
    NOT   R4, R0      ; negate R0 for comparisons
    ADD   R4, R4, #1
    ADD   R2, R1, #0  ; initialize ptr to beginning of string
FC1    LDR   R3, R2, #0 ; read character
    BRz   FC2        ; if null, we're done
    ADD   R3, R3, R4  ; see if matches input char
    BRz   FC2        ; if yes, we're done
    ADD   R2, R2, #1  ; increment pointer
    BRnzp FC1
FC2    LD    R3, FCR3  ; restore registers
    LD    R4, FCR4    ;
    RET                               ; and return
```

Library Routines

Vendor may provide object files containing useful subroutines

- don't want to provide source code -- intellectual property
- assembler/linker must support EXTERNAL symbols (or starting address of routine must be supplied to user)

```
...  
.EXTERNAL SQRT  
  
...  
LD    R2, SQAddr    ; load SQRT addr  
JSRR  R2
```

```
...  
SQAddr .FILL      SQRT
```

Using JSRR, because we don't know whether SQRT is within 1024 instructions.