

Chapter 10

And, Finally...

The Stack

Stack: An Abstract Data Type

An important abstraction that you will encounter in many applications.

We will describe three uses:

Interrupt-Driven I/O

- **The rest of the story...**

Evaluating arithmetic expressions

- **Store intermediate results on stack instead of in registers**

Data type conversion

- **2's comp binary to ASCII strings**

Stacks

A LIFO (last-in first-out) storage structure.

- The **first** thing you put in is the **last** thing you take out.
- The **last** thing you put in is the **first** thing you take out.

This means of access is what defines a stack, not the specific implementation.

Two main operations:

PUSH: add an item to the stack

POP: remove an item from the stack

A Physical Stack

Coin rest in the arm of an automobile

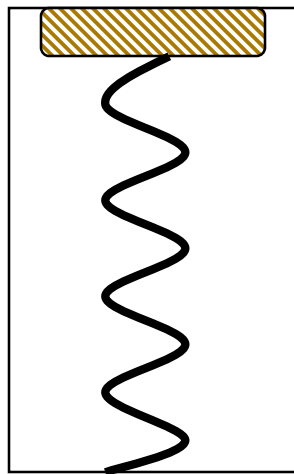

Initial State

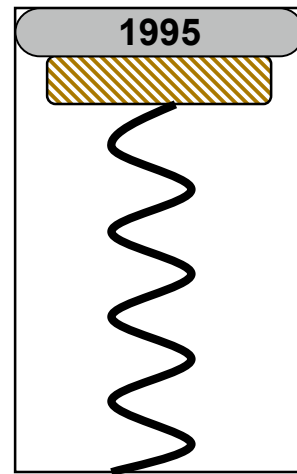

After
One Push

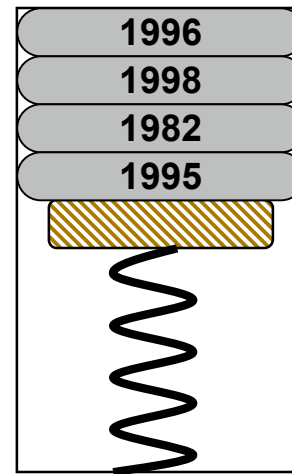

After Three
More Pushes

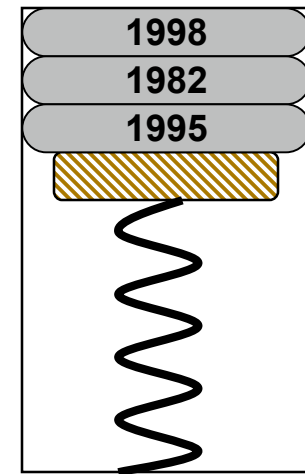

After
One Pop

First quarter out is the last quarter in.

A Hardware Implementation

Data items move between registers

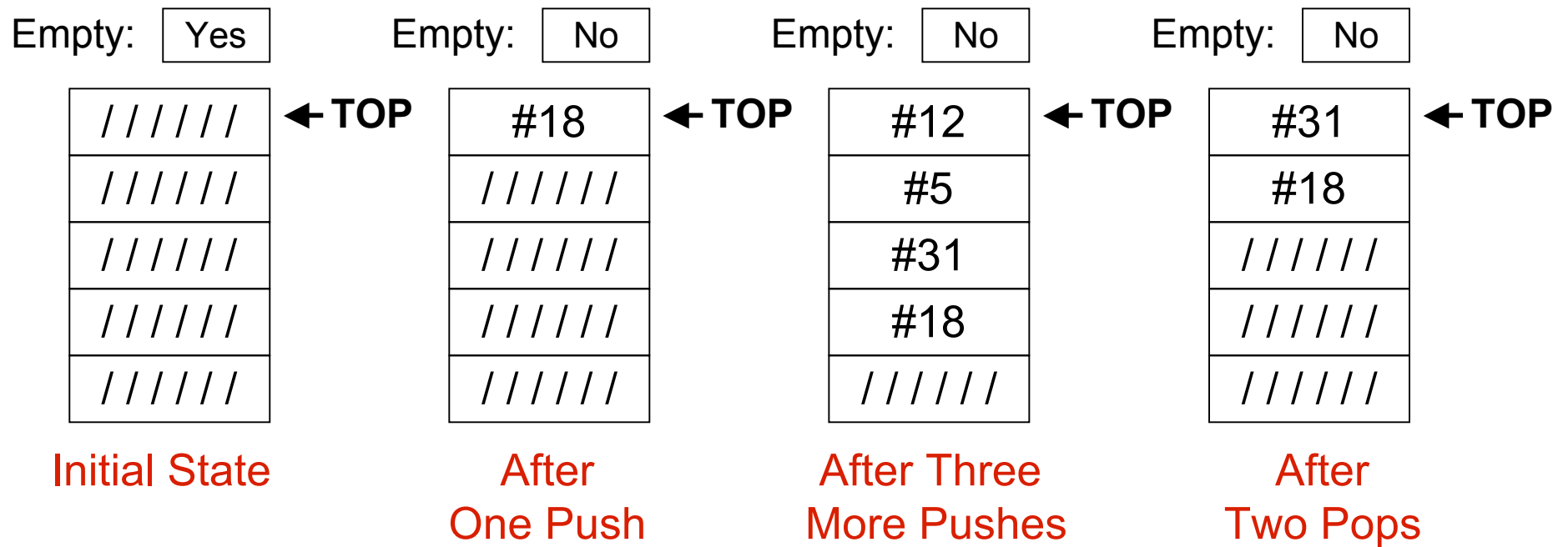

A Software Implementation

Data items don't move in memory,
just our idea about where the TOP of the stack is.

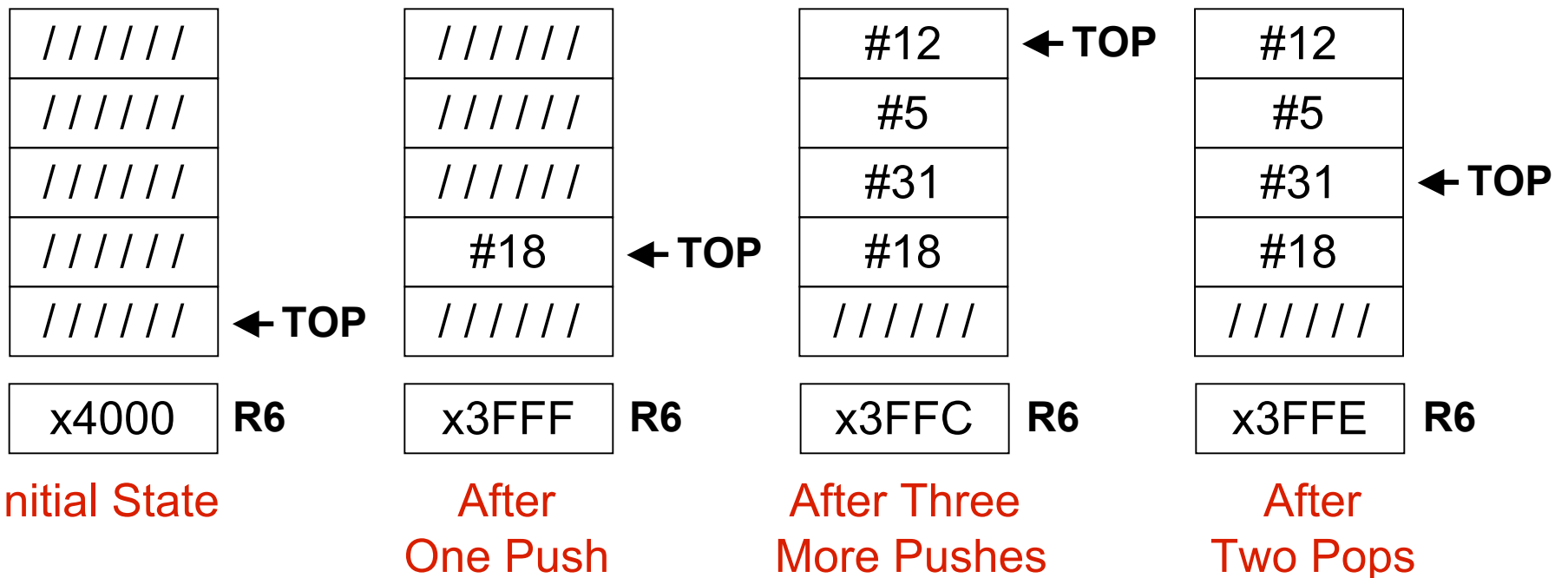

By convention, R6 holds the Top of Stack (TOS) pointer.

Basic Push and Pop Code

For our implementation, stack grows downward
(when item added, TOS moves closer to 0)

Push

```
ADD    R6, R6, #-1 ; decrement stack ptr
STR    R0, R6, #0  ; store data (R0)
```

Pop

```
LDR    R0, R6, #0  ; load data from TOS
ADD    R6, R6, #1  ; decrement stack ptr
```

Pop with Underflow Detection

If we try to pop too many items off the stack, an **underflow** condition occurs.

- Check for underflow by checking TOS before removing data.
- Return status code in R5 (0 for success, 1 for underflow)

```
POP    LD    R1, EMPTY    ; EMPTY = -x4000
      ADD  R2, R6, R1    ; Compare stack pointer
      BRz  FAIL          ; with x3FFF
      LDR  R0, R6, #0
      ADD  R6, R6, #1
      AND  R5, R5, #0    ; SUCCESS: R5 = 0
      RET
FAIL   AND  R5, R5, #0    ; FAIL: R5 = 1
      ADD  R5, R5, #1
      RET
EMPTY  .FILL xC000
```

Push with Overflow Detection

If we try to push too many items onto the stack, an **overflow** condition occurs.

- Check for underflow by checking TOS before adding data.
- Return status code in R5 (0 for success, 1 for overflow)

```
PUSH  LD   R1, MAX      ; MAX = -x3FFB
      ADD  R2, R6, R1   ; Compare stack pointer
      BRz  FAIL        ; with x3FFF
      ADD  R6, R6, #-1
      STR  R0, R6, #0
      AND  R5, R5, #0   ; SUCCESS: R5 = 0
      RET
FAIL  AND  R5, R5, #0   ; FAIL: R5 = 1
      ADD  R5, R5, #1
      RET
MAX   .FILL xC005
```

Interrupt-Driven I/O (Part 2)

Interrupts were introduced in Chapter 8.

1. External device signals need to be serviced.
2. Processor saves state and starts service routine.
3. When finished, processor restores state and resumes program.

Interrupt is an unscripted subroutine call, triggered by an external event.

Chapter 8 didn't explain how (2) and (3) occur, because it involves a **stack**.

Now, we're ready...

Processor State

What state is needed to completely capture the state of a running process?

Processor Status Register

- Privilege [15], Priority Level [10:8], Condition Codes [2:0]



Program Counter

- Pointer to next instruction to be executed.

Registers

- All temporary state of the process that's not stored in memory.

Where to Save Processor State?

Can't use registers.

- Programmer doesn't know when interrupt might occur, so she can't prepare by saving critical registers.
- When resuming, need to restore state exactly as it was.

Memory allocated by service routine?

- Must save state before invoking routine, so we wouldn't know where.
- Also, interrupts may be nested – that is, an interrupt service routine might also get interrupted!

Use a stack!

- Location of stack “hard-wired”.
- Push state to save, pop to restore.

Supervisor Stack

A special region of memory used as the stack for interrupt service routines.

- **Initial Supervisor Stack Pointer (SSP) stored in Saved.SSP.**
- **Another register for storing User Stack Pointer (USP): Saved.USP.**

Want to use R6 as stack pointer.

- **So that our PUSH/POP routines still work.**

When switching from User mode to Supervisor mode (as result of interrupt), save R6 to Saved.USP.

Invoking the Service Routine – The Details

1. If **Priv = 1** (user),
Saved.USB = R6, then R6 = Saved.SSP.
2. Push PSR and PC to Supervisor Stack.
3. Set **PSR[15] = 0** (supervisor mode).
4. Set **PSR[10:8]** = priority of interrupt being serviced.
5. Set **PSR[2:0] = 0**.
6. Set MAR = x01**vv**, where **vv** = 8-bit interrupt vector provided by interrupting device (e.g., keyboard = x80).
7. Load memory location (M[x01**vv**]) into MDR.
8. Set **PC** = MDR; now first instruction of ISR will be fetched.

Note: This all happens between the **STORE RESULT** of the last user instruction and the **FETCH** of the first ISR instruction.

Returning from Interrupt

Special instruction – RTI – that restores state.



1. **Pop PC from supervisor stack.** ($PC = M[R6]$; $R6 = R6 + 1$)
2. **Pop PSR from supervisor stack.** ($PSR = M[R6]$; $R6 = R6 + 1$)
3. **If $PSR[15] = 1$, $R6 = \text{Saved.USP}$.**
(If going back to user mode, need to restore User Stack Pointer.)

RTI is a privileged instruction.

- **Can only be executed in Supervisor Mode.**
- **If executed in User Mode, causes an exception.**
(More about that later.)

Example (1)

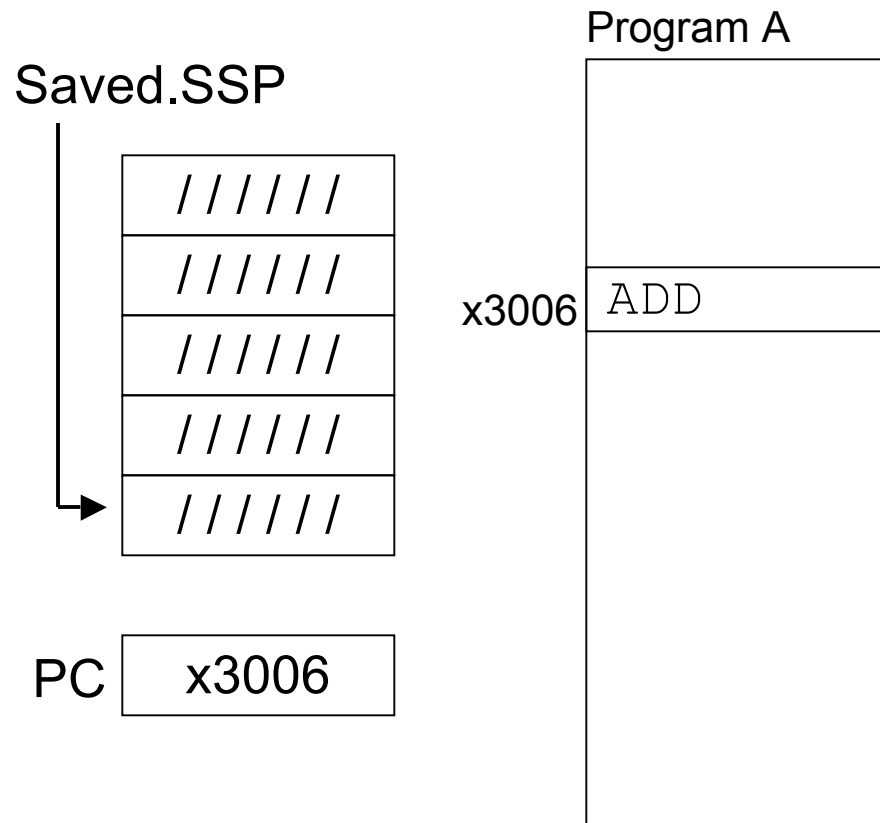

Executing ADD at location x3006 when Device B interrupts.

Example (2)

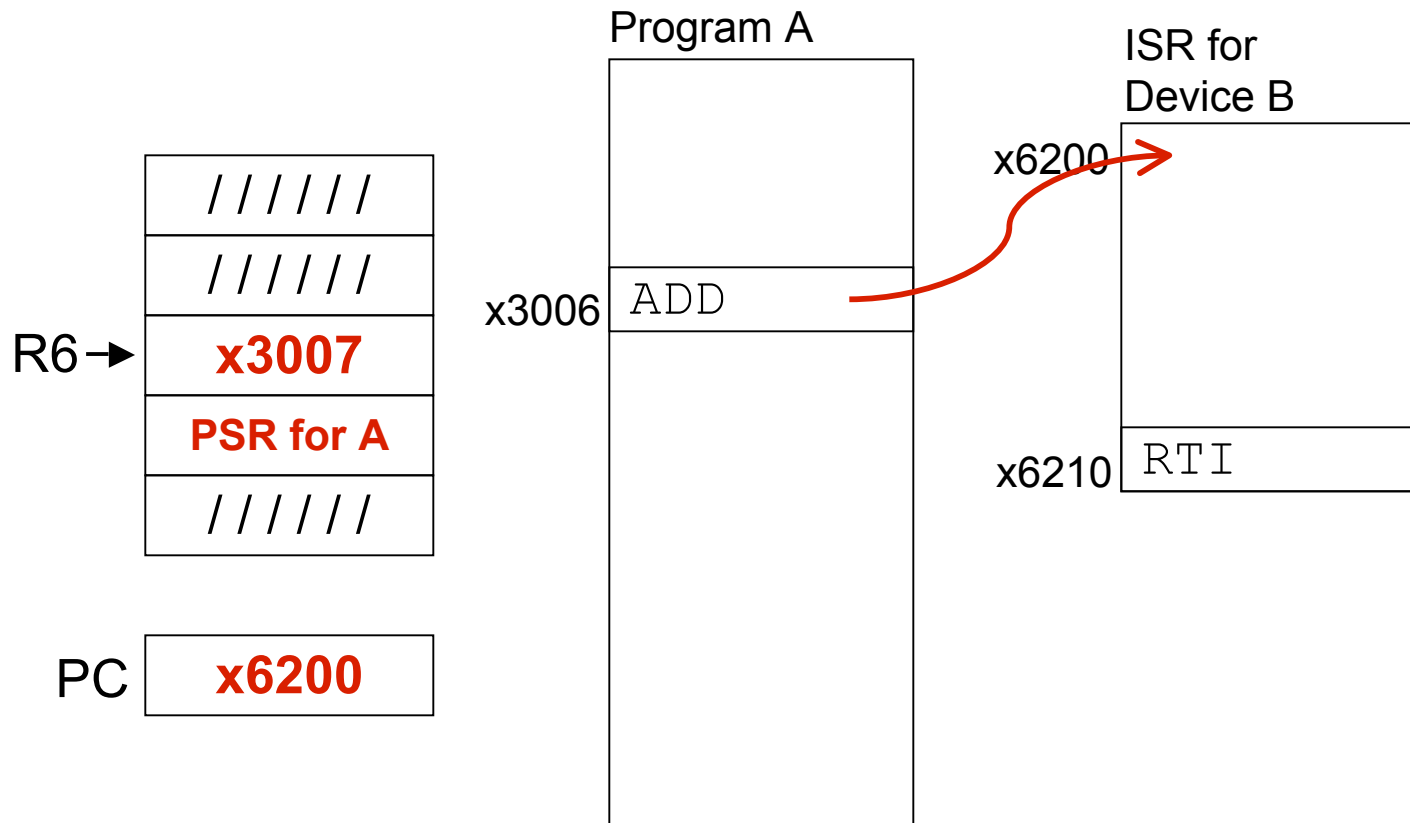

Saved.USB = R6. R6 = Saved.SSP.
Push PSR and PC onto stack, then transfer to
Device B service routine (at x6200).

Example (3)

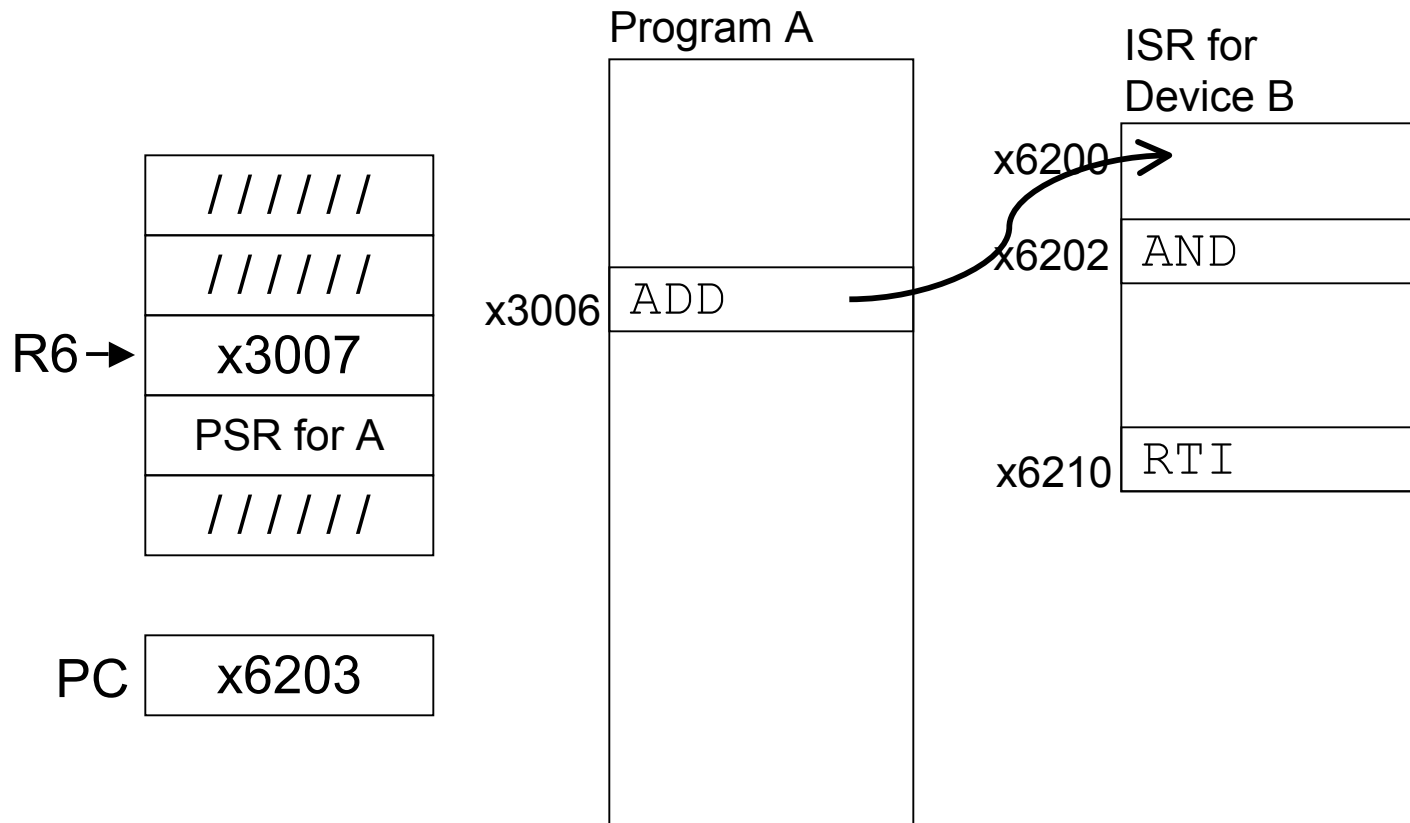

Executing AND at x6202 when Device C interrupts.

Example (5)

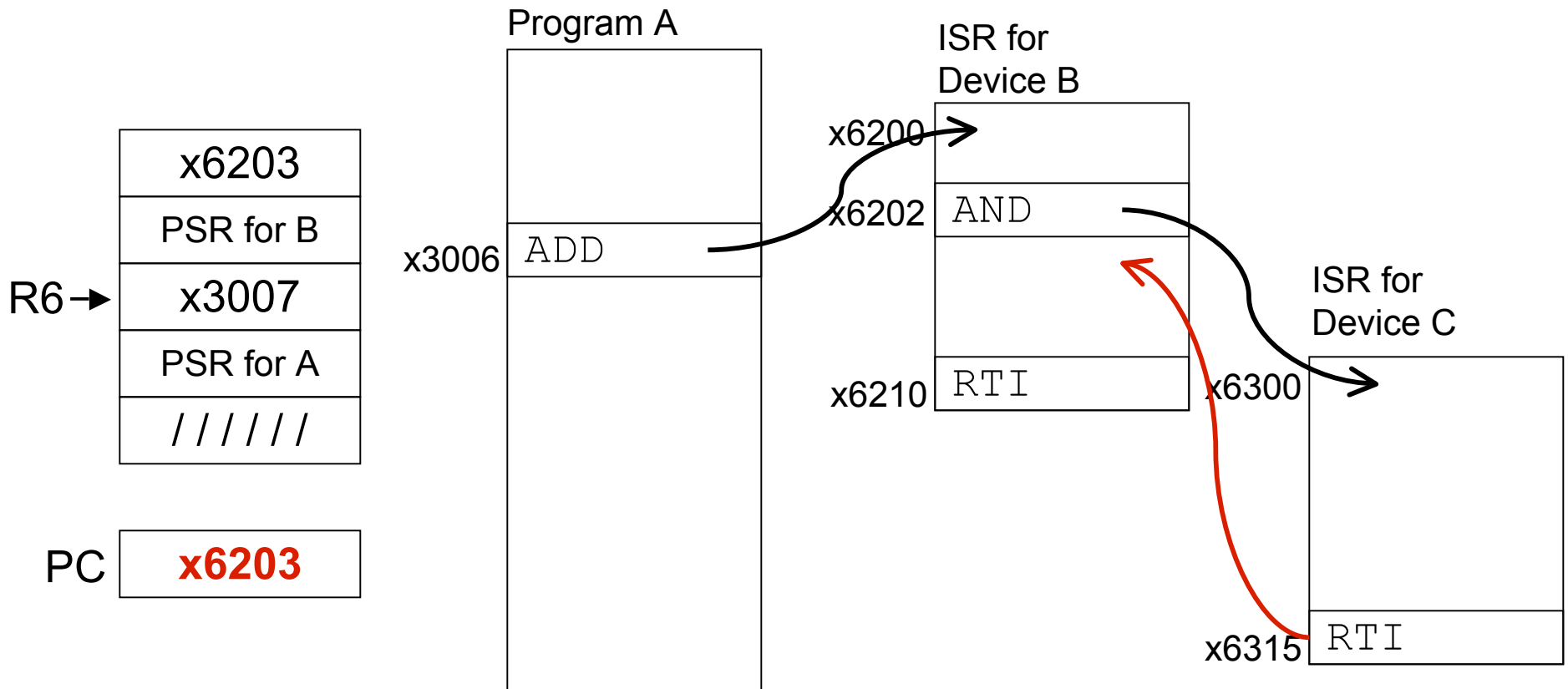

Execute RTI at x6315; pop PC and PSR from stack.

Example (6)

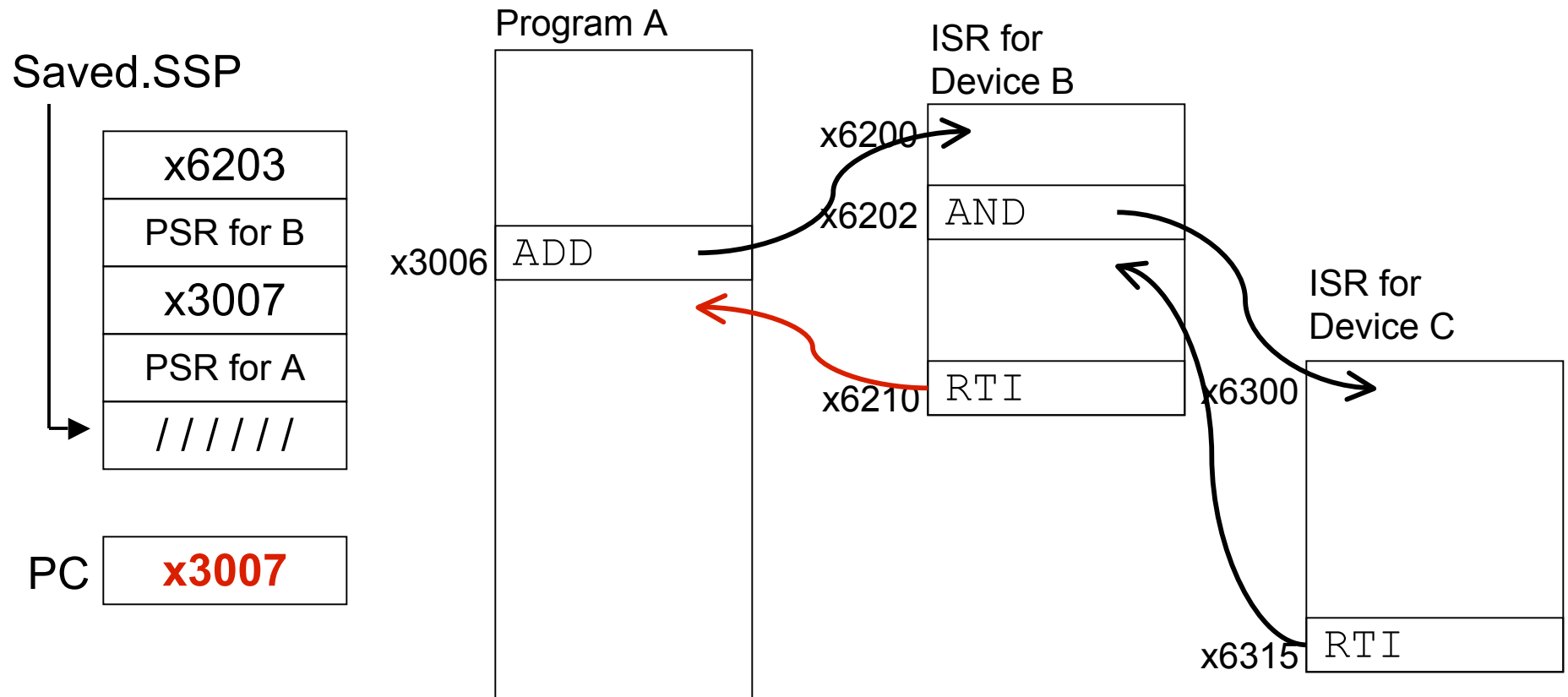

Execute RTI at x6210; pop PSR and PC from stack.
Restore R6. Continue Program A as if nothing happened.

Exception: Internal Interrupt

When something unexpected happens inside the processor, it may cause an exception.

Examples:

- Privileged operation (e.g., RTI in user mode)
- Executing an illegal opcode
- Divide by zero
- Accessing an illegal address (e.g., protected system memory)

Handled just like an interrupt

- Vector is determined internally by type of exception
- Priority is the same as running program

Arithmetic Using a Stack

Instead of registers, some ISA's use a stack for source and destination operations: a **zero-address** machine.

- Example:
ADD instruction pops two numbers from the stack, adds them, and pushes the result to the stack.

Evaluating $(A+B) \cdot (C+D)$ using a stack:

- (1) push A
- (2) push B
- (3) ADD
- (4) push C
- (5) push D
- (6) ADD
- (7) MULTIPLY
- (8) pop result

Why use a stack?

- Limited registers.
- Convenient calling convention for subroutines.
- Algorithm naturally expressed using FIFO data structure.

Example: OpAdd

POP two values, ADD, then PUSH result.

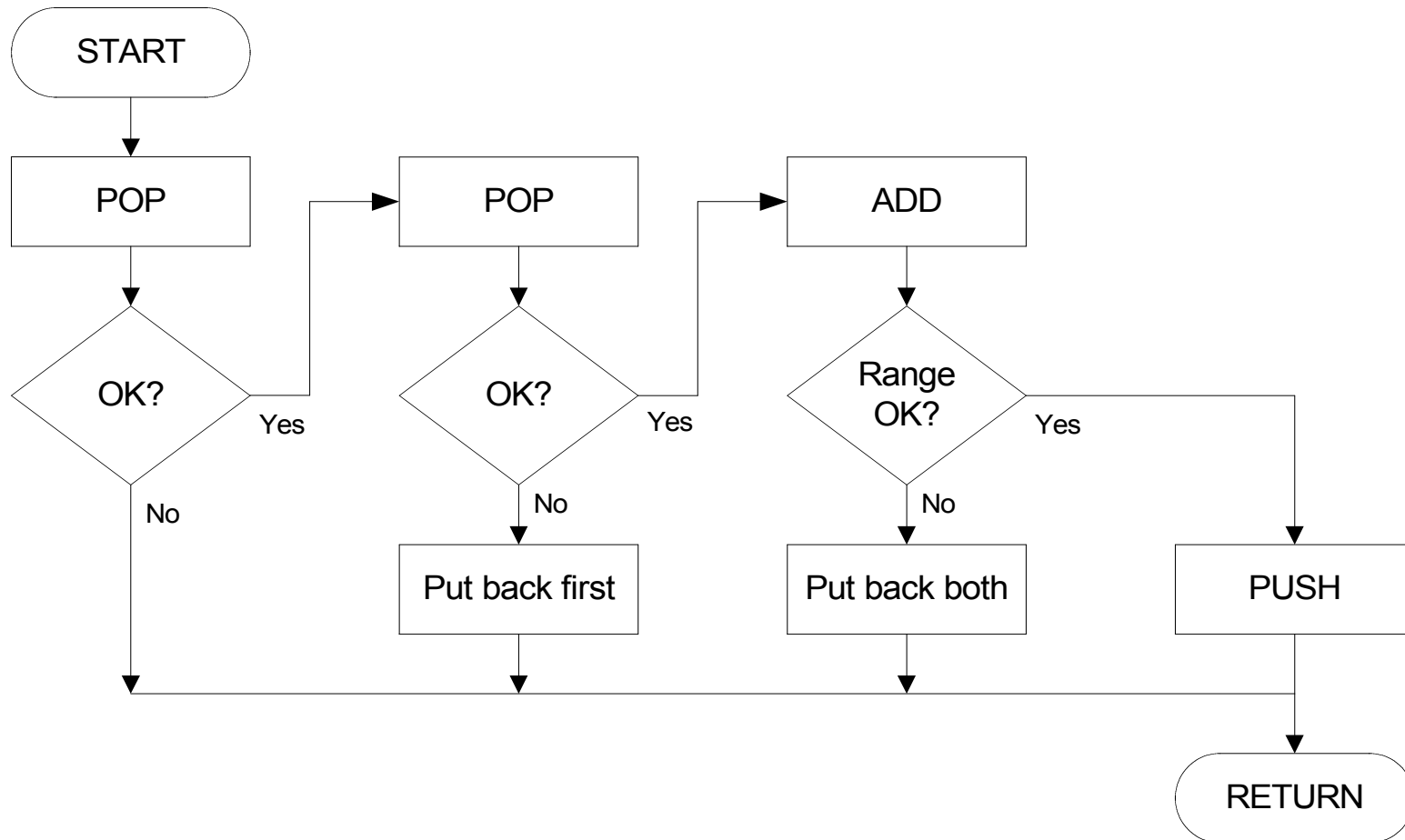

Example: OpAdd

```
OpAdd      JSR  POP           ; Get first operand.
           ADD  R5,R5,#0      ; Check for POP success.
           BRp  Exit         ; If error, bail.
           ADD  R1,R0,#0      ; Make room for second.
           JSR  POP           ; Get second operand.
           ADD  R5,R5,#0      ; Check for POP success.
           BRp  Restore1     ; If err, restore & bail.
           ADD  R0,R0,R1      ; Compute sum.
           JSR  RangeCheck    ; Check size.
           BRp  Restore2     ; If err, restore & bail.
           JSR  PUSH          ; Push sum onto stack.
           RET

Restore2   ADD  R6,R6,#-1     ; Decr stack ptr (undo POP)
Restore1   ADD  R6,R6,#-1     ; Decr stack ptr
Exit      RET
```

Data Type Conversion

Keyboard input routines read ASCII characters, not binary values.

Similarly, output routines write ASCII.

Consider this program:

```
TRAP  x23          ; input from keybd
ADD   R1, R0, #0   ; move to R1
TRAP  x23          ; input from keybd
ADD   R0, R1, R0   ; add two inputs
TRAP  x21          ; display result
TRAP  x25          ; HALT
```

User inputs **2** and **3** -- what happens?

Result displayed: **e**

Why? ASCII '2' (**x32**) + ASCII '3' (**x33**) = ASCII 'e' (**x65**)

ASCII to Binary

Useful to deal with mult-digit decimal numbers

Assume we've read three ASCII digits (e.g., "259") into a memory buffer.

How do we convert this to a number we can use?

x32	'2'
x35	'5'
x39	'9'

- Convert first character to digit (subtract x30) and multiply by 100.
- Convert second character to digit and multiply by 10.
- Convert third character to digit.
- Add the three digits together.

Multiplication via a Lookup Table

How can we multiply a number by 100?

- One approach:
Add number to itself 100 times.
- Another approach:
Add 100 to itself <number> times. (Better if number < 100.)

Since we have a small range of numbers (0-9),
use number as an index into a lookup table.

Entry 0: $0 \times 100 = 0$

Entry 1: $1 \times 100 = 100$

Entry 2: $2 \times 100 = 200$

Entry 3: $3 \times 100 = 300$

etc.

Code for Lookup Table

```
; multiply R0 by 100, using lookup table
;
    LEA  R1, Lookup100    ; R1 = table base
    ADD  R1, R1, R0       ; add index (R0)
    LDR  R0, R1, #0       ; load from M[R1]
    ...
Lookup100 .FILL 0      ; entry 0
          .FILL 100   ; entry 1
          .FILL 200   ; entry 2
          .FILL 300   ; entry 3
          .FILL 400   ; entry 4
          .FILL 500   ; entry 5
          .FILL 600   ; entry 6
          .FILL 700   ; entry 7
          .FILL 800   ; entry 8
          .FILL 900   ; entry 9
```

Complete Conversion Routine (1 of 3)

```
; Three-digit buffer at ASCIIBUF.  
; R1 tells how many digits to convert.  
; Put resulting decimal number in R0.  
ASCIItoBinary  AND    R0, R0, #0    ; clear result  
                ADD    R1, R1, #0    ; test # digits  
                BRz   DoneAtoB      ; done if no digits  
  
;  
                LD     R3, NegZero   ; R3 = -x30  
                LEA   R2, ASCIIBUF  
                ADD   R2, R2, R1  
                ADD   R2, R2, #-1    ; points to ones digit  
  
;  
                LDR   R4, R2, #0     ; load digit  
                ADD   R4, R4, R3     ; convert to number  
                ADD   R0, R0, R4     ; add ones contrib
```

Conversion Routine (2 of 3)

```
    ADD    R1, R1, #-1    ; one less digit
    BRz   DoneAtoB      ; done if zero
    ADD    R2, R2, #-1    ; points to tens digit
;
    LDR   R4, R2, #0     ; load digit
    ADD   R4, R4, R3     ; convert to number
    LEA   R5, Lookup10  ; multiply by 10
    ADD   R5, R5, R4
    LDR   R4, R5, #0
    ADD   R0, R0, R4     ; adds tens contrib
;
    ADD   R1, R1, #-1    ; one less digit
    BRz   DoneAtoB      ; done if zero
    ADD   R2, R2, #-1    ; points to hundreds
                        ; digit
```

Conversion Routine (3 of 3)

```
LDR  R4, R2, #0    ; load digit
ADD  R4, R4, R3    ; convert to number
LEA  R5, Lookup100 ; multiply by 100
ADD  R5, R5, R4
LDR  R4, R5, #0
ADD  R0, R0, R4    ; adds 100's contrib

;
DoneAtoB          RET
NegZero           .FILL  xFFD0    ; -x30
ASCIIBUF         .BLKW  4
Lookup10         .FILL  0
                 .FILL  10
                 .FILL  20
...
Lookup100       .FILL  0
                 .FILL  100
...
```

Binary to ASCII Conversion

Converting a 2's complement binary value to a three-digit decimal number

- Resulting characters can be output using OUT

Instead of multiplying, we need to **divide by 100 to get hundreds digit.**

- Why wouldn't we use a lookup table for this problem?
- Subtract 100 repeatedly from number to divide.

First, check whether number is negative.

- Write sign character (+ or -) to buffer and make positive.

Binary to ASCII Conversion Code (part 1 of 3)

```
; R0 is between -999 and +999.  
; Put sign character in ASCIIBUF, followed by three  
; ASCII digit characters.
```

```
BinaryToASCII  LEA R1, ASCIIBUF   ; pt to result string  
                ADD R0, R0, #0     ; test sign of value  
                BRn NegSign  
                LD  R2, ASCIIplus  ; store '+'  
                STR R2, R1, #0  
                BRnzp Begin100  
NegSign        LD  R2, ASCIIneg    ; store '-'  
                STR R2, R1, #0  
                NOT R0, R0         ; convert value to pos  
                ADD R0, R0, #1
```

Conversion (2 of 3)

```
Begin100      LD  R2, ASCIIoffset
              LD  R3, Neg100
Loop100      ADD R0, R0, R3
              BRn End100
              ADD R2, R2, #1 ; add one to digit
              BRnzp Loop100
End100      STR R2, R1, #1 ; store ASCII 100's digit
              LD  R3, Pos100
              ADD R0, R0, R3 ; restore last subtract
;
              LD  R2, ASCIIoffset
              LD  R3, Neg10
Loop100      ADD R0, R0, R3
              BRn End10
              ADD R2, R2, #1 ; add one to digit
              BRnzp Loop10
```

Conversion Code (3 of 3)

```
End10          STR R2, R1, #2   ; store ASCII 10's digit
               ADD R0, R0, #10 ; restore last subtract
;
               LD  R2, ASCIIoffset
               ADD R2, R2, R0   ; convert one's digit
               STR R2, R1, #3   ; store one's digit
               RET

;
ASCIIplus     .FILL x2B   ; plus sign
ASCIIneg     .FILL x2D   ; neg sign
ASCIIoffset  .FILL x30   ; zero
Neg100       .FILL xFF9C ; -100
Pos100       .FILL #100
Neg10        .FILL xFFF6 ; -10
```