

Improving the Effectiveness of ATM Traffic Control over Hybrid Fiber-Coax Networks

Nada Golmie[†]

Mark D. Corner[†]

Jörg Liebeherr*

David H. Su[†]

[†] National Institute of Standards and Technology
Gaithersburg, MD 20899

* Department of Electrical Engineering
Polytechnic University
Brooklyn, NY 11201

Abstract

The IEEE 802.14 working group is currently standardizing a new media access control (MAC) protocol for the emerging Hybrid Fiber Coax (HFC) networks. Crucial for the success of 802.14 will be its ability to support higher layer traffic services, namely, ATM Constant Bit Rate (CBR), Variable Bit Rate (VBR) and Available Bit Rate (ABR) traffic classes. In this study, we investigate the interoperation of the MAC protocol, defined by 802.14, with ABR transmissions. An important finding of our study is that the bandwidth contention on the upstream channel in the HFC network may interfere with the feedback congestion control mechanisms of ABR traffic control. This interference can result in unfairness between ABR sources, and decreased utilization of the upstream HFC channel. As a solution to the problem we propose a scheme whereby the headend station of the HFC network returns congestion information contained in resource management (RM) cells to the ABR sources. The proposed mechanism can be incorporated into the ABR rate control scheme without modifying the current traffic management specifications. Numerous simulation scenarios are presented to illustrate our findings. Parts of the results have been presented to the IEEE 802.14 standard committee.

1 Introduction

The IEEE 802.14 working group is currently standardizing a media access control (MAC) protocol for the emerging Hybrid Fiber Coax (HFC) networks for providing high bandwidth residential networking services. An HFC network utilizes the in-place residential broadcast cable system. While downstream communi-

cation from the headend to the stations is free of contention, the upstream channel from the stations to the headend is a shared access channel and subject to collisions. The 802.14 working group is currently defining a contention resolution protocol that controls access to the upstream channel and resolves collisions. Crucial for the success of 802.14 will be its ability to support higher layer traffic services, namely, ATM Constant Bit Rate (CBR), Variable Bit Rate (VBR) and Available Bit Rate (ABR) traffic classes. This study explores the performance and interoperation of the MAC protocol, as defined by the 802.14 specification, with the ABR service. Using simulation experiments we evaluate the degree to which contention at the MAC layer of an HFC network interferes with the rate-based flow control mechanisms of ABR traffic. Our findings are as follows:

- *Upstream ABR Traffic:* ABR transmissions that originate inside the HFC network and have destinations outside the HFC network maintain fairness and quality-of-service (QoS) requirements.
- *Downstream ABR Traffic:* ABR traffic sources that send into an HFC network may experience unfair bandwidth allocation, even if the downstream channel of the HFC network is not congested. The unfairness in bandwidth allocation is due to contention on the upstream HFC channel. Feedback information from the destinations to the sources is delayed, and, as a result, ABR sources transmit at a reduced rate.

The contribution of this study is a proposal to solve the unfairness problem of downstream ABR traffic. In

our solution, the headend station of the HFC network generates feedback information that is returned to the ABR sources on the ATM network. The feedback is based on the load of the upstream HFC channel, where we use the backlog of the so-called grant queue at the headend station as a load indicator. We will show how the proposed solution can be incorporated into the IEEE 802.14 [8] and the ATM Traffic Management [1] specifications, with no modifications to those standards.

The remainder of the paper is organized as follows. In Section 2 we provide an overview of the MAC protocol proposed by the IEEE 802.14 working group. In Section 3 we briefly review the ABR flow control mechanism. In Section 4 we discuss the performance of ABR transmissions over HFC networks. In Section 5 we present our scheme and we offer conclusions in Section 6.

2 IEEE 802.14 Media Access Control Protocol

In an HFC network up to two thousand stations are connected to a single tree network. All stations transmit to the headend using an upstream communications channel. The transmissions on the upstream channel are divided into fixed-sized time intervals, so-called *minislots*. Stations send transmission requests to the headend in a single minislot; such a slot is then called a *contention slot* (CS). Stations send data in *data slots* (DS), which consist of multiple minislots. At the top of the cable tree, the headend station transmits feedback and data to the stations using a downstream channel. The system of upstream and downstream transmission channels is asymmetrical with typical upstream and downstream rates equaling approximately 0.5-10 Mbits/s and 30 Mbits/s, respectively. The IEEE 802.14 Medium Access Control (MAC) is only concerned with the transmission of data on the upstream channel. It operates as follows. A station with data to transmit must send a request for bandwidth on the upstream channel to the headend station. Using the downstream channel, the headend acknowledges the request or indicates that a collision has occurred. The latter initiates the collision resolution process. Once the collision is resolved, the headend stations sends a message to the station granting the use of the upstream channel. Because bandwidth is allocated by a reservation process, no collisions will occur during the transmission of data. Only transmission requests, which are transmitted in contention slots, are subject to collisions.

The collision resolution scheme adopted by the IEEE 802.14 group is based on a blocking ternary tree

splitting algorithm [3]. Tree splitting algorithms have been used in the past to improve the performance of collision access [2]. In a tree splitting algorithm, all stations that are involved in a collision split into a number of subgroups. After a collision, only the stations in the first subgroup continue the collision resolution step. The stations in the second subgroup resume the collision resolution process after all stations in the first group have successfully transmitted, and so forth. A ternary tree splitting algorithm always divides colliding stations into three subgroups. Some tree-splitting algorithms are *non-blocking*, which allows stations to transmit new requests at any time. *Blocking* tree-splitting algorithms do not allow new stations to transmit during an ongoing collision resolution process [2]. The selection of a blocking algorithm for 802.14 is intended to reduce the MAC access delay variance [5].

The current version of the MAC protocol is heavily influenced by an adaption of the tree splitting algorithm, the n-ary Stack Random Access Algorithm [9, 3, 4]. The collision resolution scheme used in this paper is based on the status of July 1997 as reflected by [8].

3 ABR Service Overview

The Available Bit Rate (ABR) service in ATM networks [1] is intended to carry data traffic, which requires a high degree of data integrity and incurs some transfer delays. An endsystem that establishes an ABR connection specifies its maximum required bandwidth, referred to as *peak cell rate* (PCR), and minimum usable bandwidth, referred to as the *minimum cell rate* (MCR). During the lifetime of an ABR connection, the network can set the actual traffic rate, the *allowed cell rate* or ACR, of the connection to any value which satisfies $MCR \leq ACR \leq PCR$.

An end-to-end flow control mechanism, known as the rate-based mechanism, controls the ABR source rate as follows. A source starts sending its data at some negotiated Initial Cell Rate (ICR). Periodically, the source sends Resource Management (RM) cells along with data cells to its destination. When RM cells arrive at the destination, they are returned to the source with some flow control information, such as congestion status and expected cell rate. Any intermediate network switching node can update the feedback information contained in the RM cell on its way back to the source. Based on this feedback information, the source adjusts its transmission rate. If a returning RM cell indicates congestion in the network, the source decreases its Allowed Cell Rate (ACR) multiplicatively by the Rate Decrease Factor (RDF). Otherwise, the

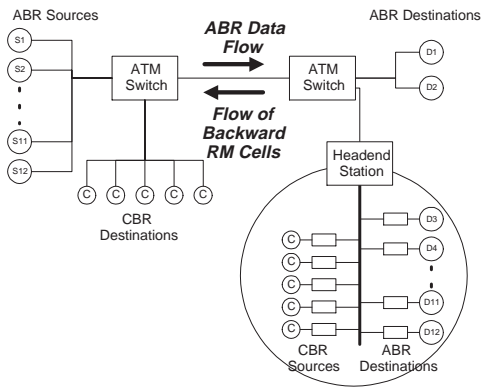

Figure 1: Downstream Configuration.

source increases its ACR additively by a Rate Increase Factor (RIF).

In [1], two modes of switch behavior are considered: EFCI (Explicit Forward Congestion Indication) and ER (Explicit Rate). When in a congested state, a switch in EFCI mode (EFCI switch) sets the EFCI bit in the header of all data cells that are forwarded to its destination. The destination conveys the congestion information back to the source by setting the Congestion Indication (CI) field in a returning RM cell. A switch in ER mode (ER switch) is more sophisticated in that it monitors its traffic and calculates an average fair share of its capacity per active connection. This quantity is called ‘explicit rate’ and is given directly to the source. In comparison, an ER switch provides more efficient and fair control of the source rate than an EFCI switch. Due the use of different parameters for the calculation of the explicit rate, there are several variations for ER switch mechanisms. In this paper we use an ER mechanism developed at NIST [7]; this mechanism attempts to achieve maximum network stability in terms of ACR and buffer occupancy oscillations.

4 Effectiveness of ABR Flow Control Traffic over HFC

The key issue for transmitting ABR traffic over an HFC network is whether the QOS guarantees of ABR connections can be maintained. As far as ABR QOS is concerned, the ABR service category definition in [1] clearly states that no bound is required on the delay or the delay variation experienced by a given connection. There is, however, a requirement to provide a low cell loss ratio for those connections whose end-stations obey a specified reference behavior. Also, it is assumed that all connections experiencing the same congestion conditions should receive an equal (‘fair’)

share of the network bandwidth.

In order to evaluate the degree to which contention in an HFC network interferes with the feedback loop of the ABR rate control mechanisms, we have built a simulator of a combined ATM/HFC network. The primary concern in our study is how well the MAC layer in HFC networks supports the ABR service.

4.1 ATM/HFC Simulation

We have built a simulation of an ATM/HFC network to measure the degree to which an HFC network can impact the effectiveness of ABR rate control in an ATM network. The implementation was done using the NIST ATM Network Simulator [6]. The ATM simulation package was extended by a module for an HFC network with an interface to ATM components.

The simulated network scenario is depicted in Figure 1. The network consists of two interconnected ATM switches which are connected to sources and destinations of ATM traffic. One of the switches is attached to the headend station of an HFC network; the HFC network itself has stations that are sources and destinations of ATM traffic. Traffic sources send either CBR or ABR traffic. The link bandwidth available to ABR traffic between the ATM switches is set to 6 Mbits/s. By making this link the bottleneck in all simulation scenarios, we enforce that the ABR rate control algorithms are active throughout all simulations. In all simulation experiments we assume that cells are generated at a persistent constant rate for both ABR and CBR applications, set to 0.5 Mbits/s for the ABR applications and to 0.13 Mbits/s for CBR applications. The MAC simulation parameters are set according to Table 1. Table 2 describes the simulation parameters used for ABR sources, and Table 3 describes the parameters for ABR switches. The buffers sizes of all ATM switches are limited to 10,000 cells.

In the simulations we measure the transient behavior of the system. Since it is our goal to study (1) the fairness of bandwidth allocation among ABR connections, and (2) the impact of delayed feedback on the ABR sources, we take the following measurements:

- Buffer Occupancy measured at the the congested ATM link.
- Allowed Cell Rate (ACR) of the ABR traffic sources.

The simulation scenario shown in Figure 1 is referred to as Downstream Configuration where we evaluate ABR connections that have the destination inside

| Simulation Parameter | Values |
|--|---------------------------------|
| Distance from nearest/furthest station to headend | 25/80 km |
| Downstream data transmission rate | Not considered limiting |
| Upstream data transmission rates channels | 8.192 Mbits/sec |
| Propagation delay | 5 μ s/km for coax and fiber |
| Length of simulation run | 10 sec |
| Length of run prior to gathering statistics | 10% of simulated time |
| Guardband and pre-amble between stations transmissions | Duration of 5 bytes |
| Data Slot size | 64 bytes |
| Contention Slot size | 16 bytes |
| DS/CS size ratio | 4:1 |
| Frame size | 2.27 ms (Max 160 CSs) |
| Maximum request size per Contention Slot | 16 |
| Number of Contention Slots | 20 |
| Number of Data Slots | 35 |
| Headend processing delay | 1 ms |

Table 1: MAC Parameters.

an HFC network. Both EFCI and ER switch control are considered. Note that a different configuration was used to evaluate the service given to ABR connections when the ABR sources are located inside the HFC network. Due to a lack of space we won't be able to show the results of our simulations here, but we note that if the ABR sources are located inside an HFC network, the properties of the ABR rate control algorithm with both EFCI and ER switch options are preserved and the throughput fairness of the ABR sources is maintained.

4.2 Downstream Transmissions

Next we present the outcome of the simulations for the Downstream Configuration shown in Figure 1. We will observe that the contention on the HFC network results in large oscillations, requiring a change to the ABR feedback mechanism.

In the Downstream Configuration we again have 12 ABR connections transmitting over an ATM link. All sources, labeled S1, S2, . . . , S12 are connected to an ATM switch. Destinations D1 and D2 are located outside the HFC network, and D3 – D12 are located inside the HFC network. Note that the downstream bandwidth in the HFC network, set to 30 Mbits/s, is sufficient to support the peak cell rate of all ABR connections that enter the HFC network.

In the Downstream Configuration in Figure 1 we

| Simulation Parameter | Values |
|---------------------------------|----------------|
| Number of ABR sources | 12 |
| Number of CBR sources | 50 |
| CBR Parameters | |
| Cell Rate | 0.13 Mbits/s |
| ABR Parameters | |
| Nrm (Number of RM cells) | 16 |
| ABR Bandwidth on Congested Link | 6 Mbits/s |
| Link Cell Rate | 149.76 Mbits/s |
| Initial Cell Rate (ICR) | 0.5 Mbits/s |
| Peak Cell Rate (PCR) | 2.25 Mbits/s |
| Minimum Cell Rate (MCR) | 0.149 Mbits/s |
| Rate Increase Factor (RIF) | 0.063 |
| Rate Decrease Factor (RDF) | 1/16 |
| EFCI Switch High Threshold | 225 cells |
| EFCI Switch Low Threshold | 200 cells |

Table 2: ABR System Parameters.

add a number of fifty CBR connections that transmit from inside the HFC network. The CBR connections, each transmitting at 0.13 Mbits/s for a total load of 80% of the upstream HFC channel capacity.

The results of the simulations are summarized in Figures 2, 3,4 and 5. For EFCI switch control, we observe in Figure 2 that the backlog of the ABR queue frequently reaches the maximum buffer size of 10,000 cells, resulting in high cell loss rates due to buffer overflows. Obviously, the EFCI feedback algorithm is not effective in this situation.

An analysis of the situation reveals that the buffer overflows are caused by the CBR connections that are transmitting on the upstream HFC channel. These CBR connections lead to congestion on the upstream HFC channel. As a result, the backward RM cells from the ABR connections that are transmitted on the upstream channel are being delayed at the MAC layer. This increase of the MAC delay results in a rather large cycle time in the ACR oscillations for EFCI control; almost ten seconds in Figure 3. As Figure 2 demonstrates, the excessive delays of the backward RM cells cause a breakdown of EFCI feedback control. Note that this effect applies to both ABR sources S1, S2 (where backward RM cells are returned on the HFC upstream channel) and S3 thru S12 (where backward RM cells are returned on the upstream channel).

Figures 4 and 5 demonstrate that throughput fairness is maintained under ER switch control, even though the delays of the backwards RM cells are also large if ER switch control is used. However, the ACR values of all sources stay in the expected range of 0.5

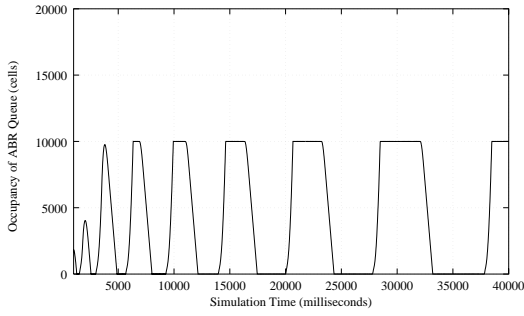

Figure 2: Downstream Transmissions: EFCI Control Mechanism, Congested Link Switch Buffer Occupancy

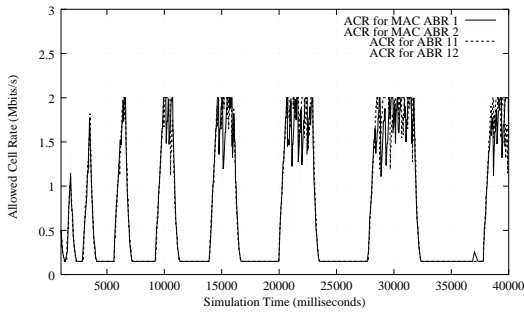

Figure 3: Downstream Transmissions: EFCI Control Mechanism, ABR Allowed Cell Rate.

Mbits/s for each ABR source.

In the next section we propose a solution to the delayed feedback with EFCI switch control when the upstream HFC channel is congested.

5 Solution to the Downstream EFCI Problem

The problem with downstream transmissions of ABR traffic in an HFC network that we observed in the previous section is somewhat counterintuitive, as the downstream capacity of the HFC network is rather large. However, as demonstrated by our simulations, the feedback cycle of EFCI switch control can collapse due to congestion on the upstream channel, independent of the bandwidth availability on the downstream channel.

In this section we present a scheme that maintains fairness and prevents a collapse of EFCI switch-control. Our solution has a number of desirable properties:

- Our scheme is implementable within the framework of the ATM Forum Traffic Management 4.0

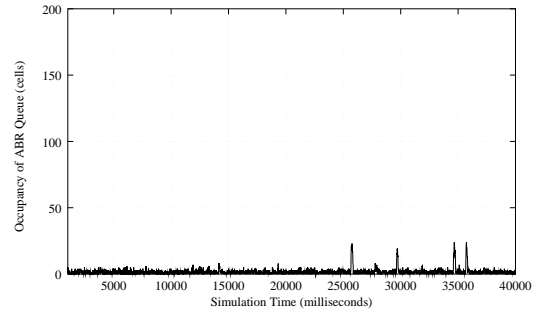

Figure 4: Downstream Transmissions: ER Control Mechanism, Congested Link Switch Buffer Occupancy.

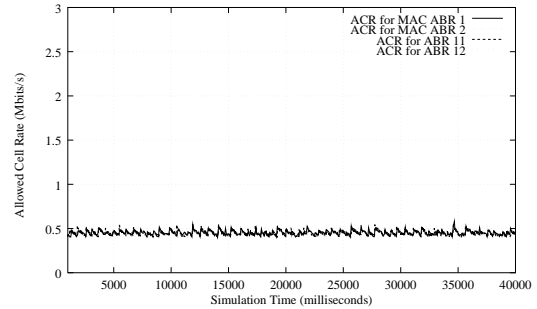

Figure 5: Downstream Transmissions: ER Control Mechanism, ABR Allowed Cell Rate.

specification [1]. No modifications to the ATM standard are required.

- The interactions between the MAC and the ATM layers is kept minimal.
- Our scheme does not result in throughput reductions or delay increases for non-ABR traffic.

Our scheme shortens the long feedback loop incurred during periods of upstream congestion of the HFC channel by passing a simple congestion indication signal from the MAC layer to the ATM layer. The solution works within the framework of the ATM Traffic Management 4.0 specification. More precisely, we exploit that [1] makes allowances for extra ABR flow control mechanisms, such as the creation of backward RM cells at the switch.

5.1 Proposed Solution

Our scheme to prevent a collapse of EFCI rate control during congestion periods in the HFC network is based on short-circuiting the feedback loop of RM cells

in situations of high load on the upstream HFC channel. The proposed scheme has three parts. First, there is a method for accurately determining the congestion level on the upstream link. Second, the MAC layer signals to the ATM layer a binary congestion notification, i.e., congestion or no congestion. Third, upon receiving a congestion notification, the ATM switch generates backward RM cells that reduce the feedback cycle time. Next we discuss the steps of our scheme in more detail.

- (1) **Congestion Measurements:** The headend of the HFC network determines the congestion state by taking a measure of the number of bandwidth grants being distributed to stations. Rather than taking instantaneous measurements of the grant queue size, the headend station tracks a weighted moving average computed as follows:

$$GQL(n) = \alpha * CL + (1 - \alpha) * GQL(n - 1)$$

Here, GQL is the smoothed value of the grant queue length, and CL is the instantaneous backlog in the grant queue, and α is a design parameter, set to 1/16 in all our simulations.

- (2) **Congestion Indication:** The headend determines if the upstream link is congested using two thresholds, and the measure of the average queue length. The headend has two design threshold values TH_{high} and TH_{low} which are used in the following manner:

$$Congestion = \begin{cases} TRUE & \text{if } GQL > TH_{high} \\ FALSE & \text{if } GQL < TH_{low} \end{cases}$$

- (3) **Interfacing with ATM rate control:**

As before, we assume that the headend station is directly connected to and integrated with an ATM switch. This allows the MAC layer to signal the ATM switch with the congestion status.

When the ATM switch receives a forward RM cell from the ATM link, it forwards the cell to the downstream link. If the switch has received notification of congestion on the upstream link, it generates a new backward RM cell with the No Increase bit set (NI = 1). This backward RM cell shortens the feedback loop for sources sending to

HFC destinations, since it short-circuits the delay that will be incurred on the congested upstream link. The generation of additional backward RM cells works within the framework of the TM 4.0 specification (Section 5.10.6 in [1]); the TM specifications permits ATM switches to generate backward RM cells at a limited rate of 10 cells/sec per connection with either the congestion indication (CI) or no increase (NI) bit set.

Next we demonstrate the impact of our solution method for the Downstream Configuration. We will see that the generation of additional backward RM cells at the headend has a profound effect on the rate oscillations and the buffer occupancy.

5.2 Evaluation

For evaluation, we use the topology and parameters from the Downstream Configuration in Figure 1. The network is enhanced by the mechanism described above. The results of the simulations are shown in Figures 6 and 7. In the simulations, we have used the following threshold values: $TH_{low} = 20$ and $TH_{high} = 40$

Comparing Figure 6 to Figure 2, we observe that the solution proposed prevents buffer overflow from occurring. Also, the ACR values of the sources in Figure 7 are not kept at their minimal (MCR) values for extended periods of time as in 3.

6 Concluding Remarks

The results presented in this contribution have pointed to a possible problem when ABR traffic is transmitted over an HFC network that runs the current version of the IEEE 802.14 MAC. We have shown that the fairness requirements of the ABR service may be violated for ABR connections that have destinations inside the HFC network. The problem results from congestion on the upstream HFC channel which may prevent backward RM cells to reach the ABR sources in a timely fashion. We proposed a solution whereby the HFC headend indicates its congestion level to the closest ATM switch, which, in turn, generates additional backward RM cells.

References

- [1] ATM Forum, ATM Forum Traffic Management Specification Version 4.0, April 1996.

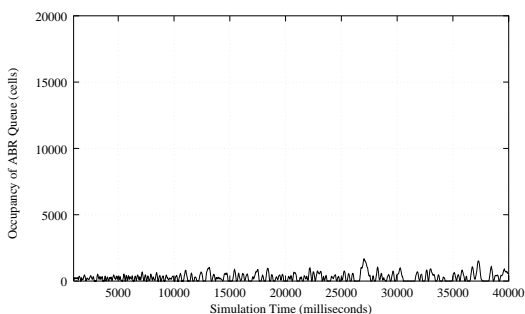

Figure 6: Downstream Transmissions (EFCI Rate Control): Congested Link Switch Buffer Occupancy

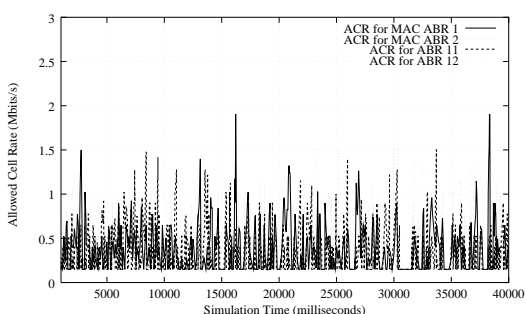

Figure 7: Downstream Transmissions (EFCI Rate Control): ABR Allowed Cell Rate.

work. In *Proceedings of the Twelfth International Conference on Computer Communications*, Seoul, Korea, August 1995.

- [8] IEEE 802.14 Working Group. Media Access and Control. Draft Supplement to IEEE Std 802.14, Draft 2, R2, July 1997.
- [9] L. Merakos and C. Bisdikian. Delay Analysis of the n-Ary Stack Random-Access Algorithm. *IEEE Transactions on Information Theory*, 1988.

- [2] D. Bertsekas and R. Gallager. *Data Networks, 2nd Ed.* Prentice Hall, 1992.
- [3] C. Bisdikian. A Review of Random Access Algorithms. Technical Report RC 20348, IBM Research Division, January 1996. T.J. Watson Research Center.
- [4] C. Bisdikian. msSTART: A Random Access Algorithm for the IEEE 802.14 HFC Network. Technical Report RC 20466, IBM Research Division, T.J. Watson Research Center, June 1996.
- [5] N. Golmie et. al. Performance Evaluation of Contention Resolution Algorithms: Ternary Tree vs p-Persistence. Contribution No. IEEE 802.14/96-241, IEEE 802.14 Working Group, November 1996.
- [6] N. Golmie et. al. The NIST ATM Network Simulator: Operation and Programming. National Institute of Standards and Technology, Internal Report 5703, August 1995.
- [7] Y. Chang et. al. A Rate Based Flow Control Switch Design for ABR Service in an ATM Net-